

FF-640 User's Guide

Contents

FF-640 User's Guide	7
Scanner Basics	8
Scanner Parts Locations	8
Scanner Parts	9
Scanner Buttons and Lights	11
Page Separation Lever	13
User Replaceable Epson Scanner Parts	14
Changing the Power Off Setting	14
Loading Originals	16
Preparing Photos for Scanning	16
Loading Photos in the Input Tray	17
Loading Multiple Sizes of Photos in the Input Tray	23
Loading a Photo with a Carrier Sheet	27
Photo Loading Capacity	30
Loading Documents in the Input Tray	31
Loading Multiple Sizes of Documents in the Input Tray	36
Document Loading Capacity	40
Loading Plastic Cards in the Input Tray	42
Plastic Card Loading Capacity	47
Loading Special Documents	48
Large or Thick Document Loading Capacity	53
Scanning	55
Starting a Scan from a Scanner Button	55
Changing the Default Scan Button Application	55
Scanning Photos with Epson FastFoto	57
Sharing Photos with Epson FastFoto	61
Uploading Photos with Epson FastFoto	62
Epson FastFoto Edit Menu	63
Available Epson FastFoto Preferences and Features	65
Scanning with Document Capture Pro in Standard View - Windows	67

Scanning with Document Capture Pro in Simple View - Windows.....	71
Scanning with Document Capture - Mac	73
Scanning with Epson Scan 2.....	76
Starting a Scan Using the Epson Scan 2 Icon	76
Starting a Scan from a Scanning Program.....	78
Scanning in Epson Scan 2.....	80
Additional Scanning Settings - Main Settings Tab.....	84
Additional Scanning Settings - Advanced Settings Tab	86
Image Format Options	88
Scan Resolution Guidelines.....	88
Scanning Special Projects.....	89
Scanning Two Originals onto One Sheet (Stitching Images) - Windows	89
Scanning Multi-Page Originals as Separate Files - Windows	92
Saving Scanned Documents as a Searchable PDF Using Epson Scan 2	96
Saving Scanned Documents as a Searchable PDF with Document Capture - Mac.....	98
Saving a Scan as an Office Format File - Windows	101
Saving a Scan as an Office Format File - Mac.....	103
Convert Scanned Documents to Editable Text (OCR).....	106
Scanning Using OCR - Windows	106
Scanning Using OCR - Mac	108
Scanning to a SharePoint Server or Cloud Service - Windows.....	111
Cleaning and Transporting Your Scanner.....	115
Cleaning Your Scanner	115
Cleaning Inside Your Scanner.....	115
Checking the Scanner Roller Counter	118
Replacing the Scanner Rollers	120
Replacing the Pickup Rollers.....	120
Replacing the Separation Rollers	127
Resetting the Scanner Roller Counter	131
Transporting Your Scanner	132
Solving Problems	134
Scanner Light Status	134
Solving Scanning Problems	135

Scanner Does Not Turn On or Turns Off Unexpectedly	136
Scanner Button Does Not Work as Expected	136
Scanning Software Does Not Operate Correctly	137
Cannot Share or Upload Photos Using FastFoto	137
Cannot Start Epson Scan 2	138
Original Feeds Incorrectly in Scanner	138
Original Jams in Scanner	139
Scanning is Slow	141
Solving Scanned Image Quality Problems	142
Image Consists of a Few Dots Only	143
Straight Lines in an Image Appear Crooked	143
Image is Distorted or Blurry	143
Image Colors are Patchy at the Edges	144
Image is Too Dark	144
Scanned Image Colors Do Not Match Original Colors	144
Back of Original Image Appears in Scanned Image	145
Scanned Characters are Blurry	145
Characters are not Recognized During Conversion to Editable Text (OCR)	145
Ripple Patterns Appear in an Image	146
Spots or Lines Appear in All Scanned Images	146
Streaks Appear in All Scanned Images	148
Scanned Image is Cropped	148
Resetting the Epson Scan 2 Settings	149
Uninstall Your Scanner Software	149
Uninstalling Scanner Software - Windows	150
Uninstalling Scanner Software - Mac	150
Where to Get Help	151
Technical Specifications	153
Windows System Requirements	153
Mac System Requirements	153
General Specifications	154
Dimension Specifications	155
Electrical Specifications	155

Environmental Specifications	156
USB Interface Specifications	157
Safety and Approvals Specifications	157
Notices	158
Important Safety Instructions.....	158
Restrictions on Copying	160
Default Delay Times for Power Management for Epson Products.....	161
Binding Arbitration and Class Waiver	161
Trademarks	164
FCC Compliance Statement.....	164
Copyright Notice.....	165
libTIFF Software Acknowledgment.....	166
libjpeg-turbo.....	166
A Note Concerning Responsible Use of Copyrighted Materials.....	167
Copyright Attribution	167

FF-640 User's Guide

Welcome to the FF-640 *User's Guide*.

For a printable PDF copy of this guide, [click here](#).

Note: This guide contains instructions for the 2.0 version of the FastFoto software. If you have an earlier version, you can download and install the latest software from the Epson support site or using the Epson Software Updater utility.

Related references

[Where to Get Help](#)

Scanner Basics

See these sections to learn about the basic features of your scanner.

[Scanner Parts Locations](#)

[User Replaceable Epson Scanner Parts](#)

[Changing the Power Off Setting](#)

Scanner Parts Locations

See these sections to identify the parts on your scanner.

[Scanner Parts](#)

[Scanner Buttons and Lights](#)

[Page Separation Lever](#)

Parent topic: [Scanner Basics](#)

Scanner Parts

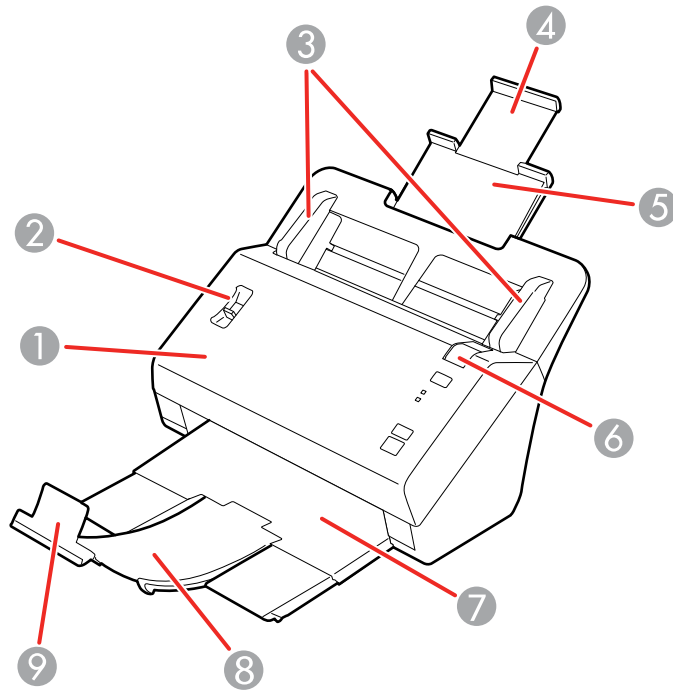

- 1 Scanner cover
- 2 Page separation lever
- 3 Edge guides
- 4 Input tray extension
- 5 Input tray
- 6 Cover open lever
- 7 Output tray
- 8 Output tray extension
- 9 Output tray extension

9 Stopper

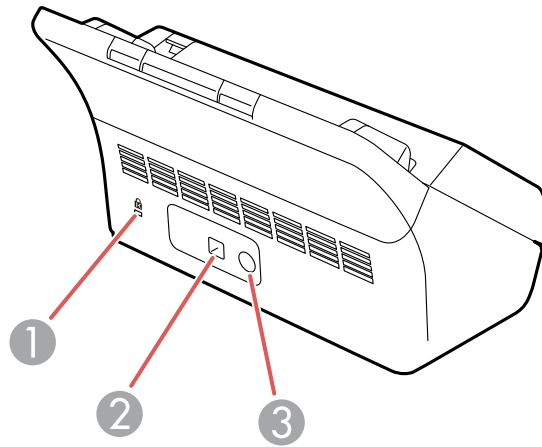

- 1 Kensington security slot
- 2 USB port
- 3 Power inlet

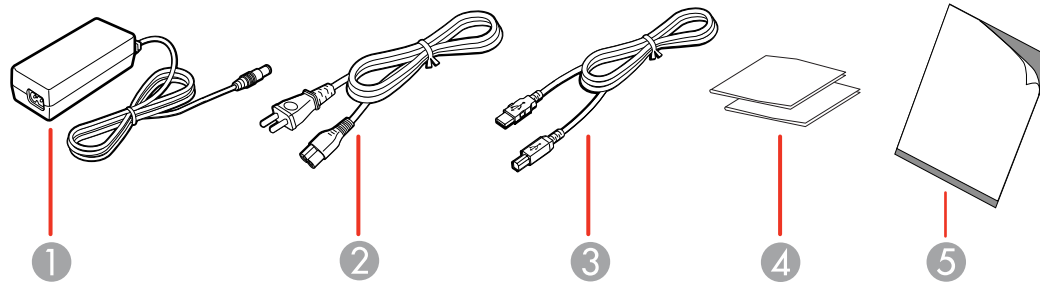

- 1 AC adapter
- 2 Power cord
- 3 USB cable
- 4 Microfiber cleaning cloths (2)

5 Carrier sheet

Parent topic: [Scanner Parts Locations](#)

Scanner Buttons and Lights

Buttons

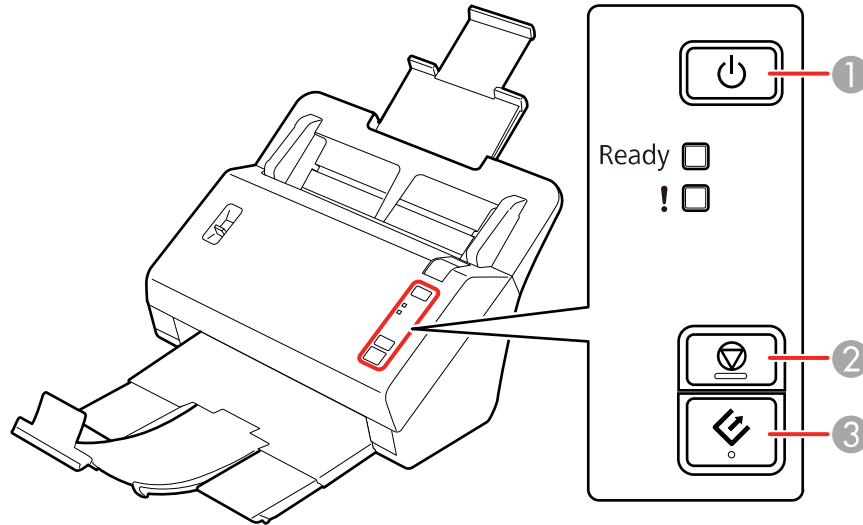

- 1 power button
- 2 stop button
- 3 scan button

Lights

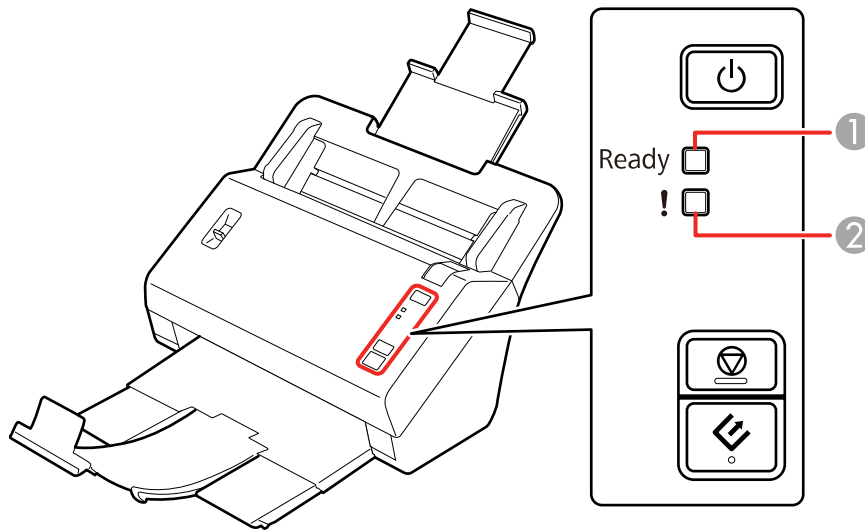

1 **Ready** light

2 **!** error light

Parent topic: [Scanner Parts Locations](#)

Related references
[Scanner Light Status](#)

Page Separation Lever

You can scan plastic cards, folded documents, envelopes, or any document or photo that requires a carrier sheet by adjusting the position of the page separation lever.

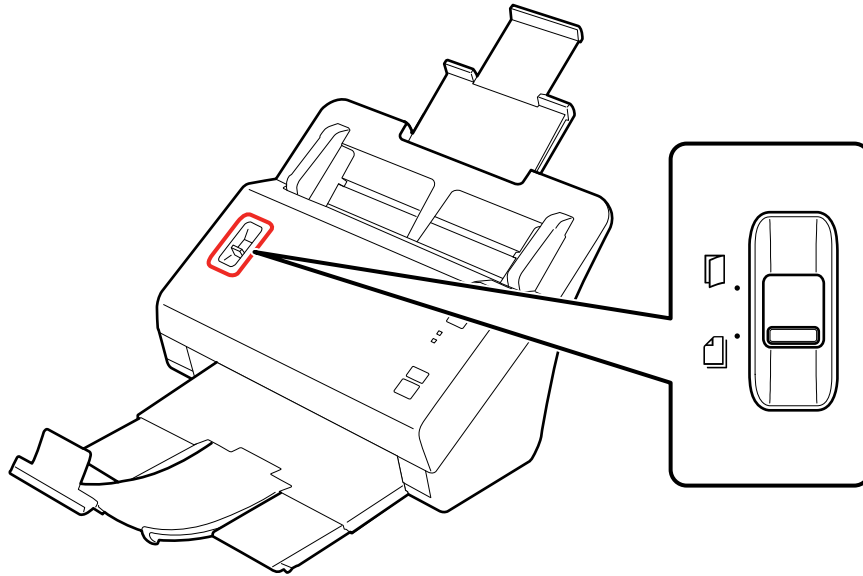

- ☐ Move the separation lever to this position only when scanning plastic cards, folded documents, envelopes, or any document or photo that requires a carrier sheet.

Note: Use a carrier sheet to load small, fragile or irreplaceable photos, valuable original documents, or artwork.

- ☐ Leave the separation lever in this position to prevent paper jams when scanning batches of photos or standard single- or multiple-page documents.

Parent topic: [Scanner Parts Locations](#)

Related tasks

[Loading Photos in the Input Tray](#)

[Loading Documents in the Input Tray](#)

[Loading Plastic Cards in the Input Tray](#)

[Loading Special Documents](#)

User Replaceable Epson Scanner Parts



You can purchase genuine Epson accessories at epson.com (U.S. sales), epson.ca (Canadian sales), or epson.com.jm (Caribbean sales). You can also purchase accessories from an Epson authorized reseller. To find the nearest one, call 800-GO-EPSON (800-463-7766) in the U.S. or 800-807-7766 in Canada.

Part	Part number
Carrier sheet	B12B813431
Roller assembly kit	B12B819231

Parent topic: [Scanner Basics](#)

Changing the Power Off Setting

You can use the Epson Scan 2 Utility to change the time period before the scanner turns off automatically.

1. Do one of the following to access the Epson Scan 2 Utility:
 - **Windows 10:** Click  and select **EPSON > Epson Scan 2 Utility**.
 - **Windows 8.x:** Navigate to the **Apps** screen and select **Epson Scan 2 Utility**.
 - **Windows (other versions):** Click  or **Start**, and select **All Programs** or **Programs**. Select **EPSON > Epson Scan 2 > Epson Scan 2 Utility**.
 - **Mac:** Open the **Applications** folder, open the **Epson Software** folder, and select **Epson Scan 2 Utility**.

2. Click the **Power Save** tab.

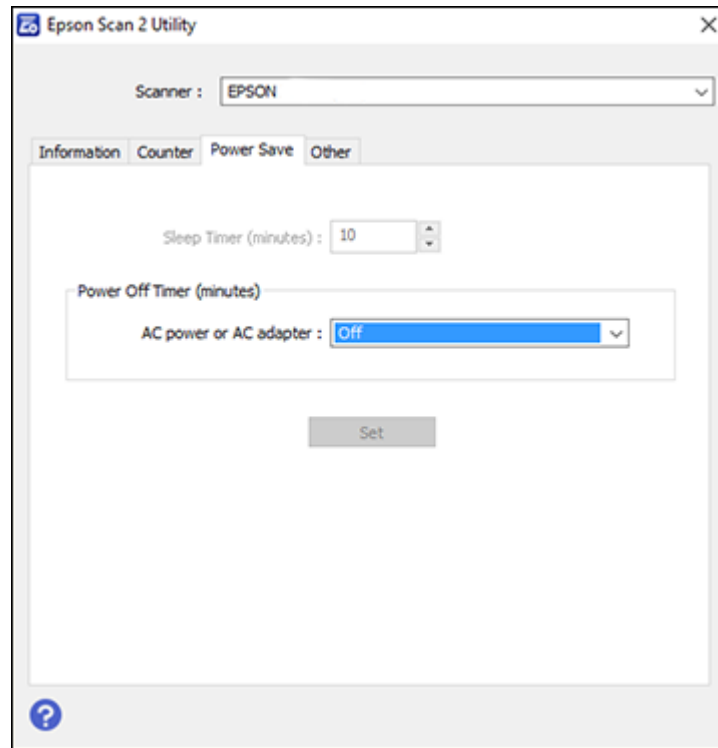

3. Select the length of time after which you want the scanner to automatically turn off when not in use as the **Power Off Timer** setting.
4. Close the Epson Scan 2 Utility.

Parent topic: [Scanner Basics](#)

Loading Originals

Follow the instructions here to load your originals into the scanner.

[Preparing Photos for Scanning](#)

[Loading Photos in the Input Tray](#)

[Loading Documents in the Input Tray](#)

[Loading Plastic Cards in the Input Tray](#)

[Loading Special Documents](#)

Preparing Photos for Scanning

FastFoto can best scan batches of photos if they are all the same size. However, FastFoto can scan photos in these sizes in a single batch: 4 × 6 inches (102 × 152 mm) and 5 × 7 inches (127 × 178 mm). To do this, you must group the photos by size.

FastFoto can use common subjects or dates to automatically create meaningful file and folder names when scanning a batch of photos.

FastFoto also allows you to add file names to photos as you scan them. Enter a subject or date when you scan a batch of photos and FastFoto will add the subject or date to the file name of each image. Organizing your photos by subject, date, or location before scanning lets FastFoto add a descriptive file name to every photo in a batch, if desired.

Before scanning multiple photos, organize and clean your photos as described here.

For more information, view this [Epson support video](#).

1. Organize your photos by subject, date, or location.
2. Group your photos by size.
3. Fan your stack of photos and make sure they are not stuck together.

Caution: Stuck photos can feed through the scanner at the same time or jam in the scanner, potentially damaging your photos or the scanner.

4. Use a soft, dry cloth to wipe the front and back of your photos to remove dust, dirt, or other particles that could potentially scratch your photos.

Caution: Because of the speed at which photos are scanned, dust particles on your photos can cause white lines to appear in scanned images, and in extreme cases can lightly scratch the protective finish on your photos. For best results, wipe off the front and back of your photos before

scanning and use the included microfiber cloth to clean the scanner rollers after every 300 scans, or even before each scanning session. See the link below for instructions on cleaning the rollers.

Parent topic: [Loading Originals](#)

Related tasks

[Cleaning Inside Your Scanner](#)

[Loading Photos in the Input Tray](#)

Loading Photos in the Input Tray

You can load up to 30 photos that meet the scanner's photo specifications in the input tray.

Note: Loading thick photos reduces the maximum number of photos that can be loaded in a single batch.

Before loading multiple photos, prepare the photos as described in the link below.

Caution: Do not load fragile or irreplaceable photos, or valuable original documents or artwork, directly into the input tray. This may wrinkle or damage the original. Load these originals one at a time using a carrier sheet.

Follow these guidelines when loading photos:

- Do not mix photos and documents.
- Scan photos of the same size in a batch.
- Do not add more photos during scanning.
- The total thickness of the photo stack must be less than 0.3 inch (8 mm) including any curve in the photos.
- Scan photos larger than 5 × 7 inches (127 × 178 mm) one at a time.

Caution: Do not scan Polaroid photos. Polaroid photos are too thick, and can damage the photo or your scanner.

1. Pull up the input tray extension, extend the output tray, and flip up the stopper.

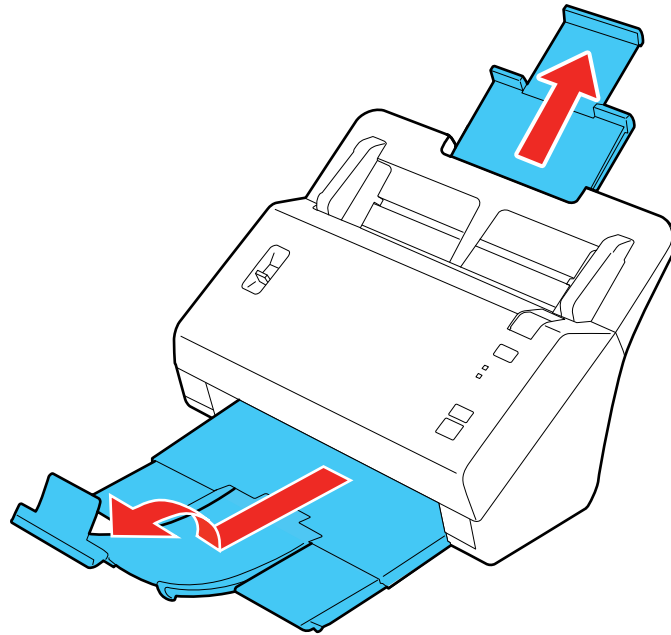

Note: If you are scanning large photos, do not flip up the stopper.

2. Slide the input tray edge guides all the way out.

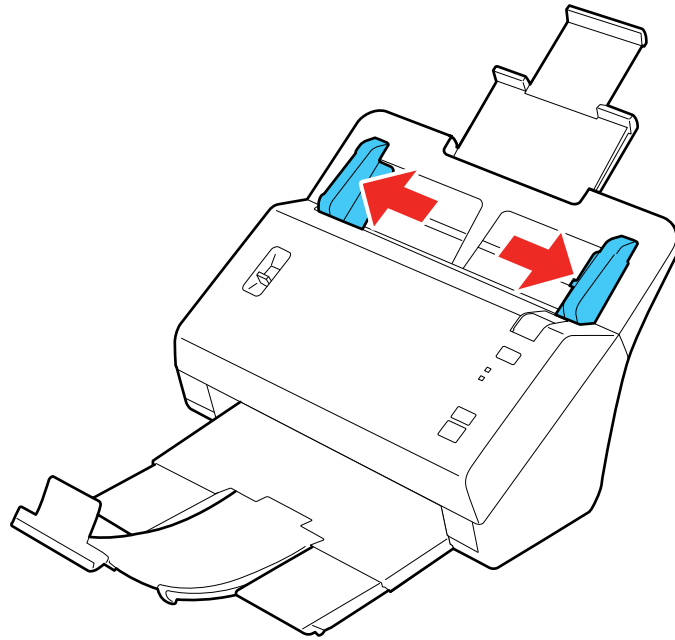

3. Check to make sure that the page separation lever is in the position shown here.

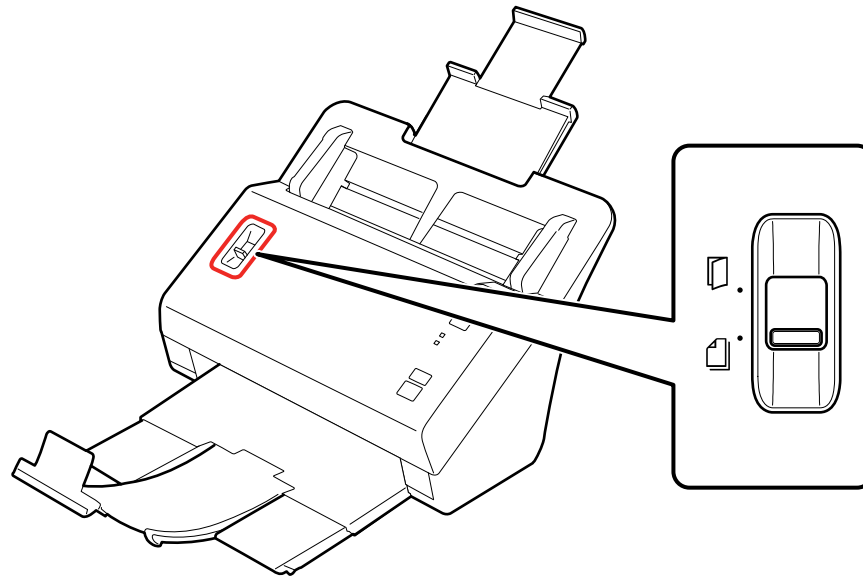

Note: To prevent paper jams, keep the lever in this position for most types of photos. If you are scanning a photo using a carrier sheet, slide it to the upper position.

4. Flip your photos so they are facedown.

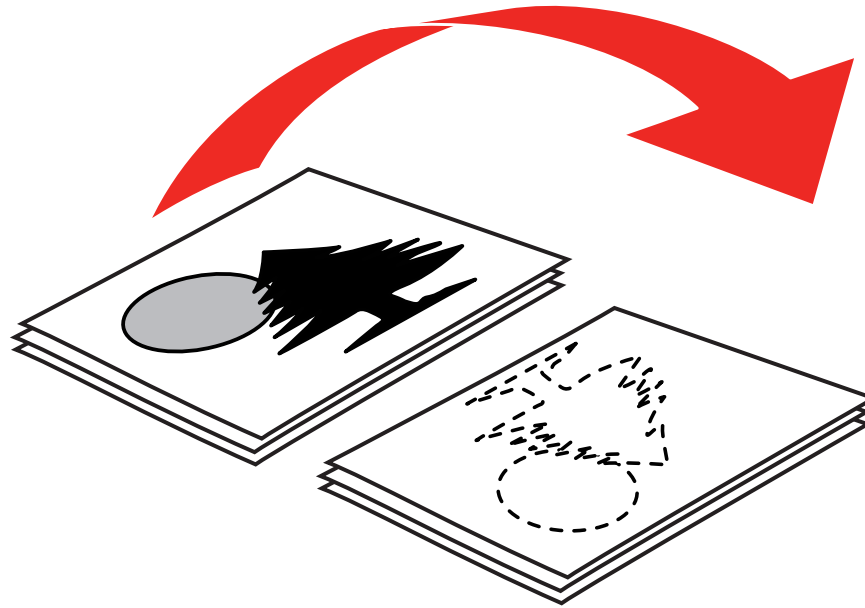

5. Fan your stack of photos and tap them gently on a flat surface to even the edges.

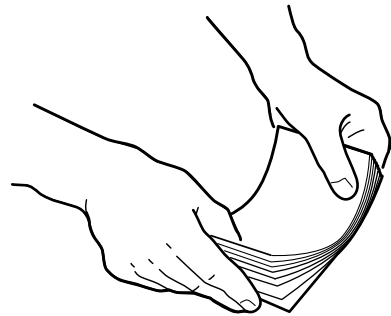

6. Load your photos into the center of the input tray facedown, in landscape orientation and top edge first, then slide them in until they meet resistance.

Note: If you have both portrait- and landscape-oriented photos in the same stack, you can rotate the portrait images after scanning.

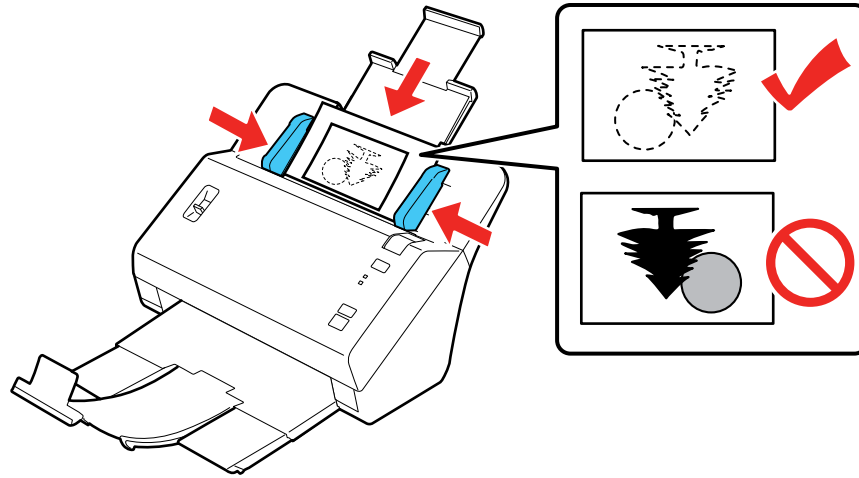

7. Slide the edge guides against the edges of the photos.

[Loading Multiple Sizes of Photos in the Input Tray](#)

[Loading a Photo with a Carrier Sheet](#)

[Photo Loading Capacity](#)

Parent topic: [Loading Originals](#)

Related references

[Epson FastFoto Edit Menu](#)

Related tasks

[Preparing Photos for Scanning](#)

Loading Multiple Sizes of Photos in the Input Tray

You can load different sizes of photos in the input tray at the same time in these sizes: 4 × 6 inches (102 × 152 mm) and 5 × 7 inches (127 × 178 mm). Do not mix photos and documents.

Scan photos larger than 5 × 7 inches (127 × 178 mm) one at a time.

Caution: Do not load fragile or irreplaceable photos, or valuable original documents or artwork, directly into the input tray. This may wrinkle or damage the original. Load these originals using the included carrier sheet.

1. Pull up the input tray extension, extend the output tray, and flip up the stopper.

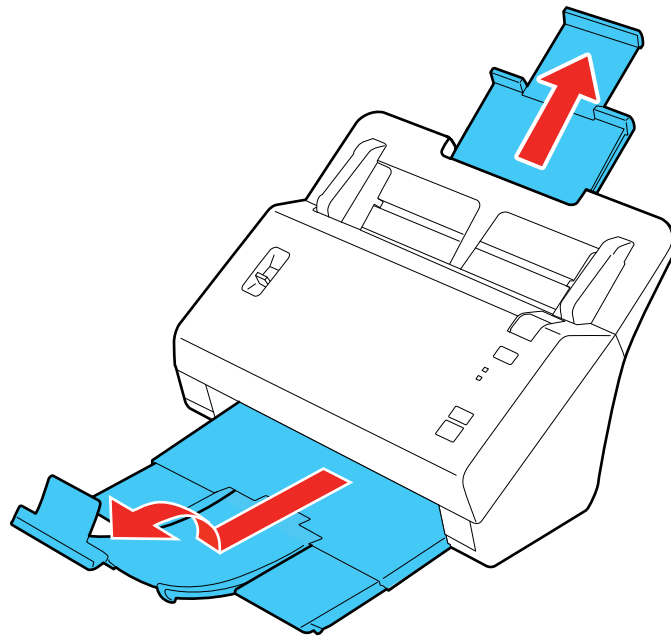

2. Slide the input tray edge guides all the way out.

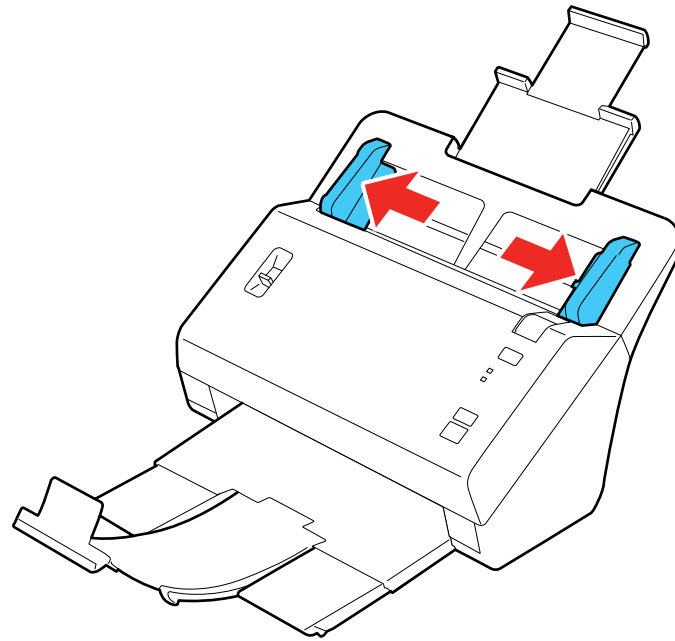

3. Check to make sure that the page separation lever is in the position shown here.

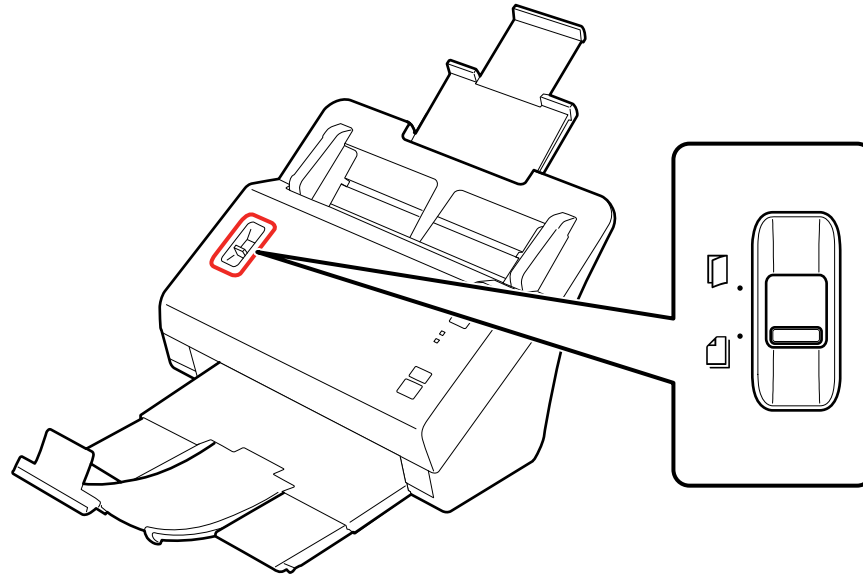

Note: To prevent jams, keep the lever in this position for most types of photos. If you are scanning a photo using a carrier sheet, slide it to the upper position.

4. Load photos in the center of the input tray in descending order of size with the largest at the back and the smallest at the front. The photos should be facedown, in landscape orientation and top edge first. Center the photos in relation to each other.

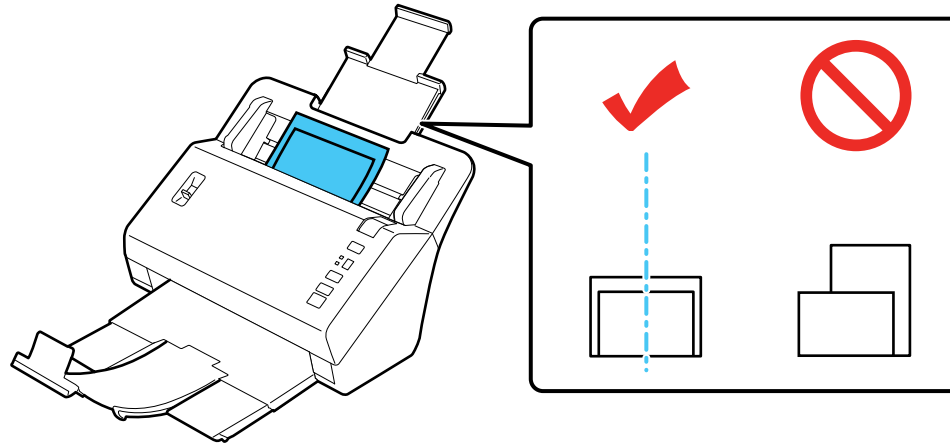

Note: If you have both portrait- and landscape-oriented photos in the same stack, you can rotate the portrait images after scanning.

5. Slide the edge guides against the edges of the widest photo.

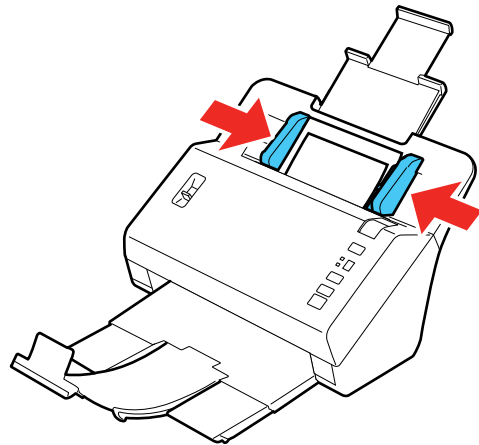

Parent topic: [Loading Photos in the Input Tray](#)

Related references

[Photo Loading Capacity](#)

Related tasks

[Preparing Photos for Scanning](#)

Loading a Photo with a Carrier Sheet

You can load a large, thick, folded, fragile, or irregularly shaped photo in the input tray using a carrier sheet. Make sure the photo meets the photo loading specifications before loading it.

For more information, view this [Epson support video](#).

1. Pull up the input tray extension, extend the output tray, and flip up the stopper.

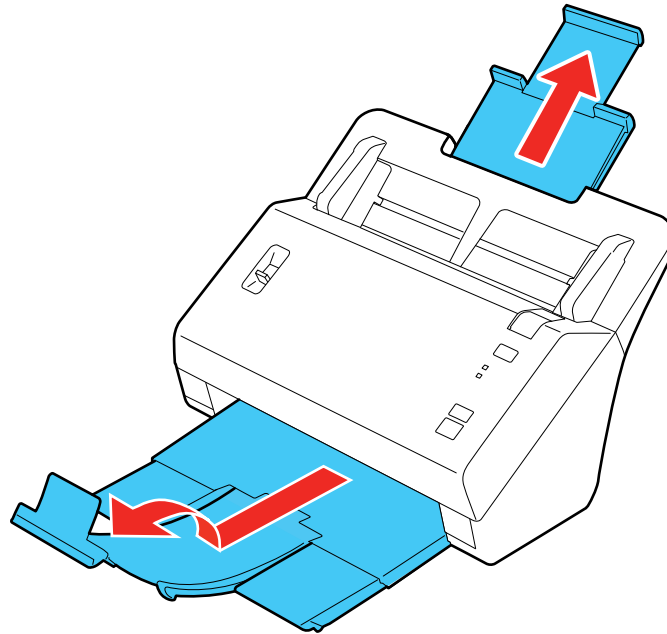

2. Slide the input tray edge guides all the way outward.

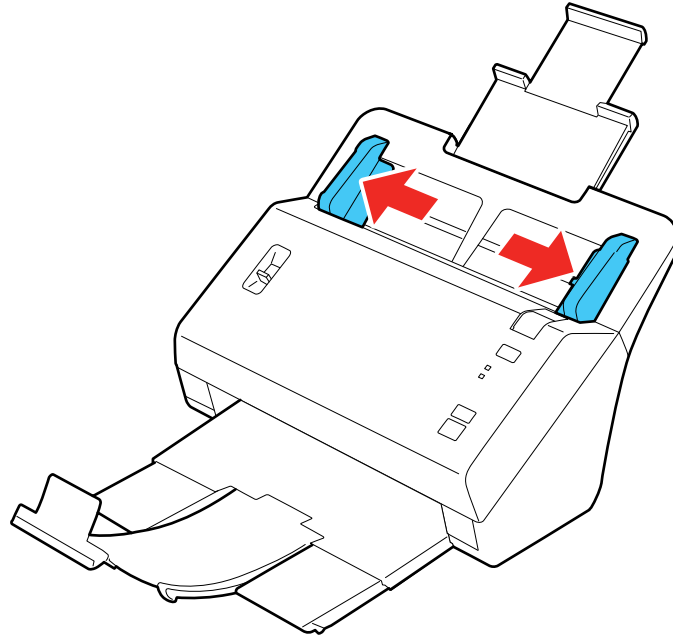

3. Insert your photo in the center of the carrier sheet with the printed side facedown and the top edge facing the arrow on the sheet.

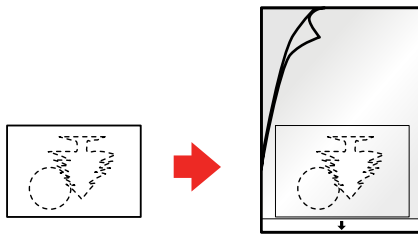

4. Load the carrier sheet in the input tray facedown with the arrow leading into the scanner.
5. Slide the carrier sheet into the scanner until it meets resistance.

6. Slide the edge guides against the edges of the carrier sheet.

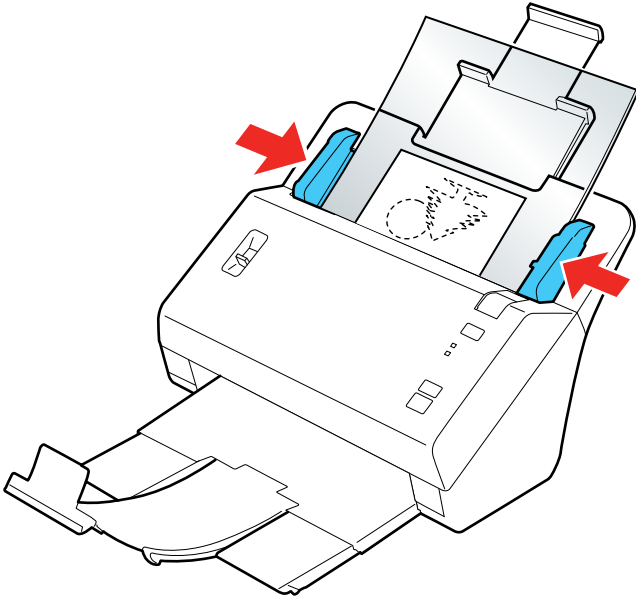

7. Set the page separation lever to the position shown here.

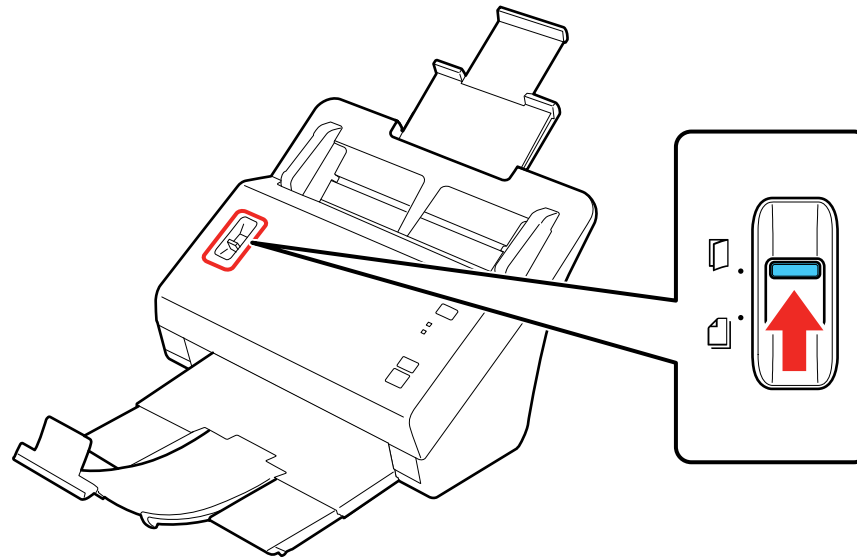

Parent topic: [Loading Photos in the Input Tray](#)

Related references

[Photo Loading Capacity](#)

Photo Loading Capacity

You can load photos that meet these specifications in your scanner.

Note: Use a carrier sheet to load large or thick photos, fragile or irreplaceable photos, valuable original documents, or artwork.

Photo size	Loading capacity
3 × 5 inches (76 × 127 mm)	30 photos (thickness less than 0.009 inch [0.23 mm] without photo curling)
4 × 6 inches (102 × 152 mm)	
5 × 7 inches (127 × 178 mm)	20 photos (thickness between 0.009 and 0.011 inch [0.24 to 0.3 mm] without photo curling)

Photo size	Loading capacity
6 × 8 inches (152 × 203 mm)	1 photo
8 × 10 inches (203 × 254 mm)	

Note: You can load up to 30 photos (combined) of the following sizes at the same time: 4 × 6 inches (102 × 152 mm) or 5 × 7 inches (127 × 178 mm).

Caution: Do not load the following types of originals in the scanner, or they may be damaged or may damage the scanner:

- Polaroid or self-processed photos
- Sticky photos
- Photos thicker than .011 inch (.31 mm)
- Photos larger than 8 × 10 inches (203 × 254 mm)
- Torn photos (unless loaded in carrier sheet)
- Wrinkled photos (unless loaded in carrier sheet)
- Curved photos where the thickness of the stack is greater than .07 inch (2 mm) (unless loaded in carrier sheet)

Parent topic: [Loading Photos in the Input Tray](#)

Related tasks

[Loading Multiple Sizes of Photos in the Input Tray](#)

[Loading a Photo with a Carrier Sheet](#)

Loading Documents in the Input Tray

You can load documents that meet the document specifications in the input tray.

Caution: Do not load fragile or irreplaceable photos, or valuable original documents or artwork, directly into the input tray. This may wrinkle or damage the original. Load these originals one at a time using a carrier sheet.

For more information, view this [Epson support video](#).

1. Pull up the input tray extension, extend the output tray, and flip up the stopper.

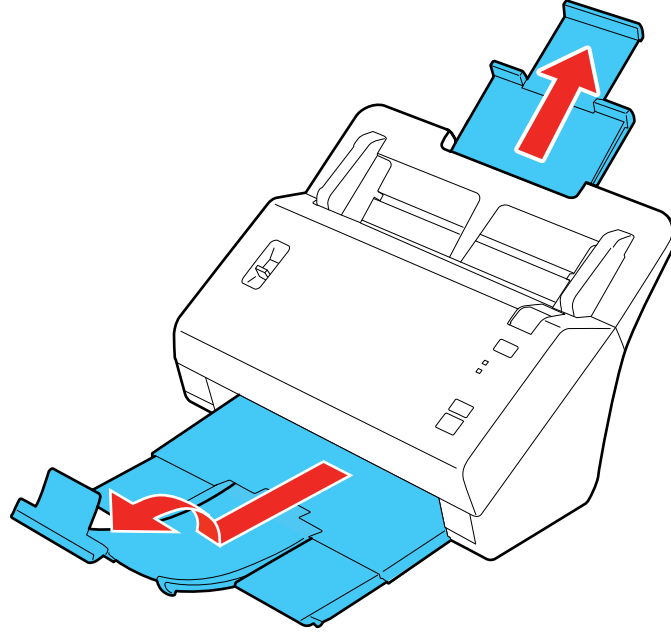

Note: If you are scanning originals longer than this, do not flip up the stopper: Letter (8.5 × 11 inches [216 × 279 mm]).

2. Slide the input tray edge guides all the way out.

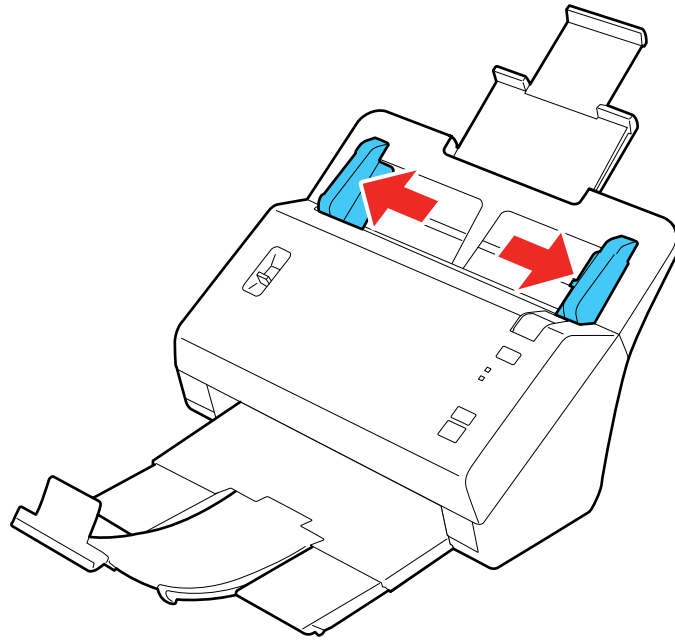

3. Check to make sure that the page separation lever is in the position shown here.

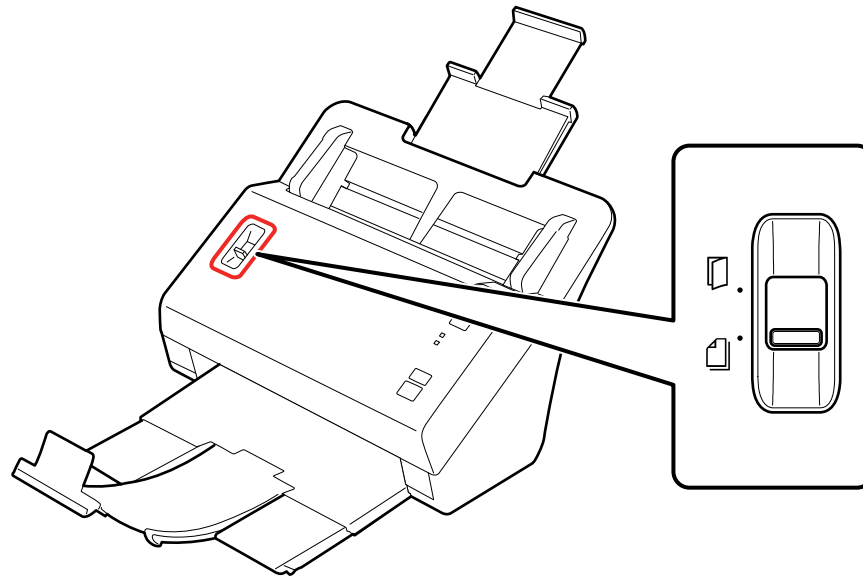

Note: To prevent paper jams, keep the lever in this position for most types of documents.

4. If you are loading a multi-page document, fan your stack of pages and tap them gently on a flat surface to even the edges.

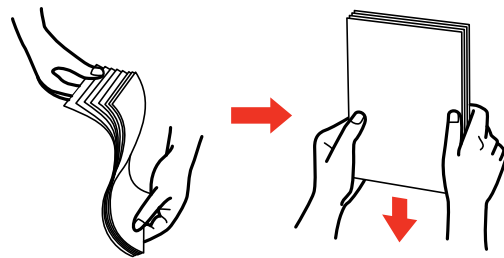

5. Slide your documents into the input tray as shown until they meet resistance. Make sure the printed side is facedown, in portrait orientation, and top edge first.

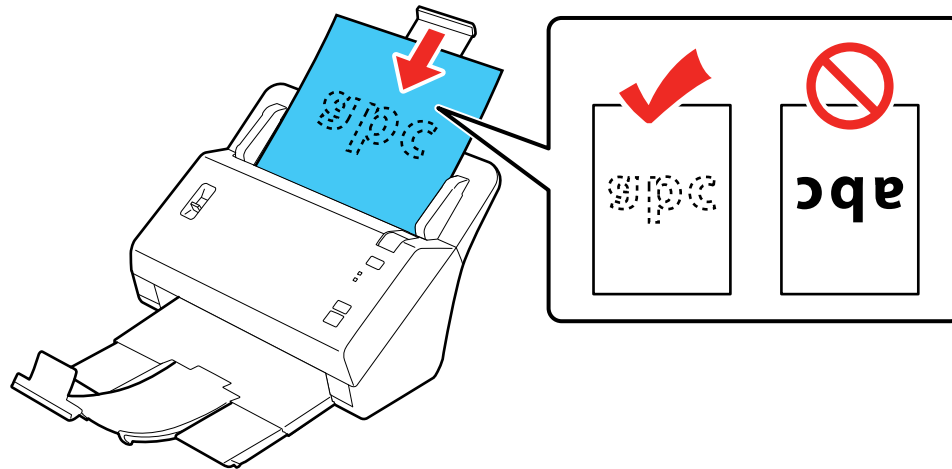

Note: If you are loading a paper business card, load it horizontally.

6. Slide the edge guides against the edges of the document.

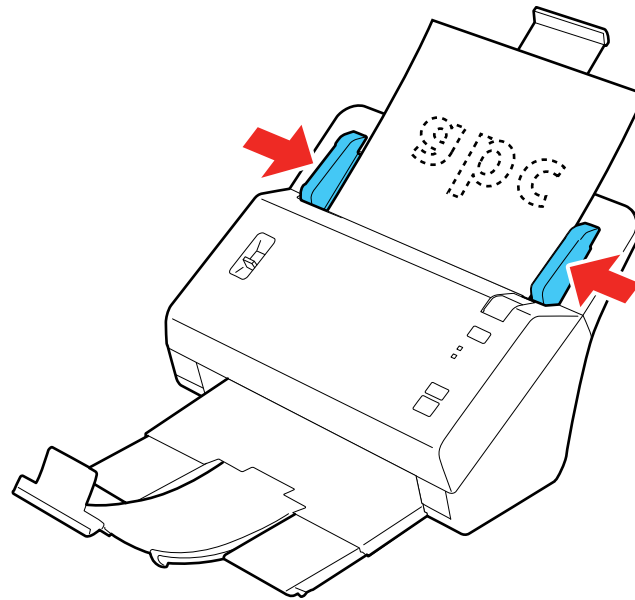

Loading Multiple Sizes of Documents in the Input Tray

Document Loading Capacity

Parent topic: [Loading Originals](#)

Loading Multiple Sizes of Documents in the Input Tray

You can load different sizes of documents in the input tray at the same time. Make sure the documents meet the document specifications of the scanner. Do not mix photos and documents in the input tray.

Caution: Do not load fragile or irreplaceable photos, or valuable original documents or artwork, directly into the input tray. This may wrinkle or damage the original. Load these originals one at a time using a carrier sheet.

For more information, view this [Epson support video](#).

1. Open the input tray and pull up its extension.

2. Pull up the input tray extension, extend the output tray, and flip up the stopper.

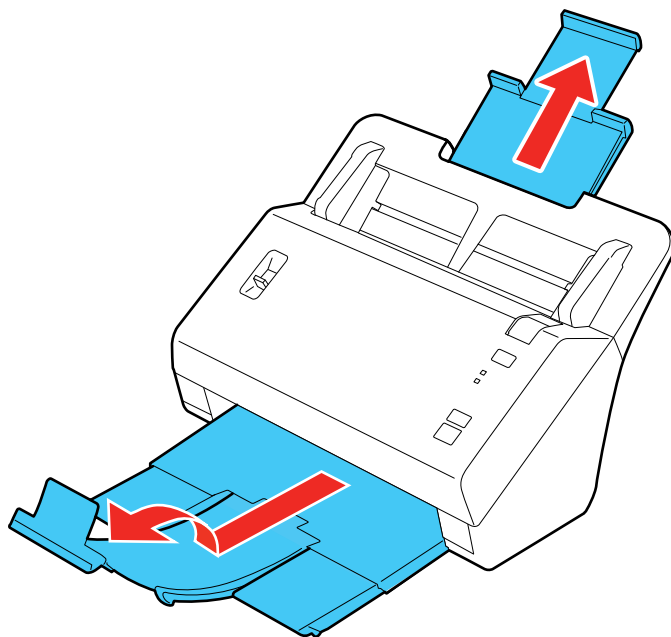

Note: If you are scanning originals longer than this, do not flip up the stopper: Letter (8.5 × 11 inches [216 × 279 mm]).

3. Slide the input tray edge guides all the way out.

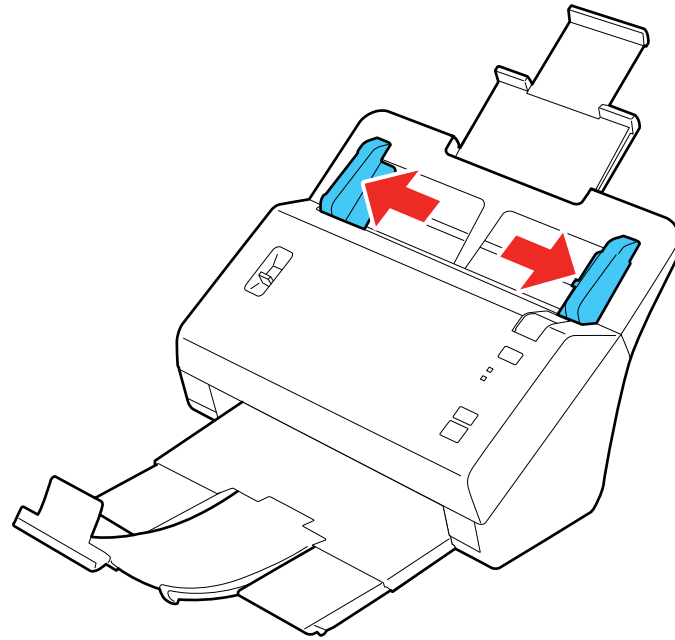

4. Check to make sure that the scan separation lever is in the position shown here.

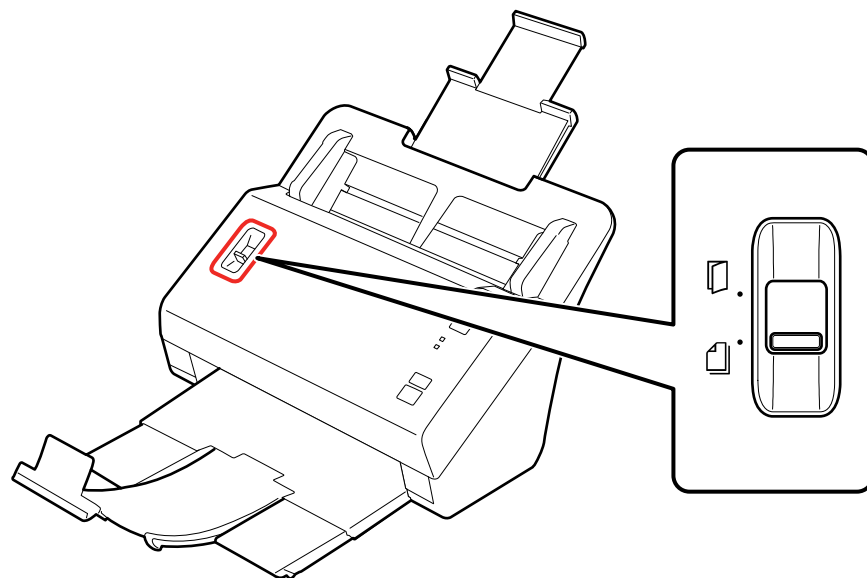

Note: To prevent paper jams, keep the lever in this position for most types of documents.

5. Load the documents in the input tray in descending order of paper size with the largest at the back and the smallest at the front. The documents should be facedown, in portrait orientation, and top edge first. Center the documents in relation to one another.

Note: If you have both portrait- and landscape-oriented photos in the same stack, you can rotate the portrait images after scanning.

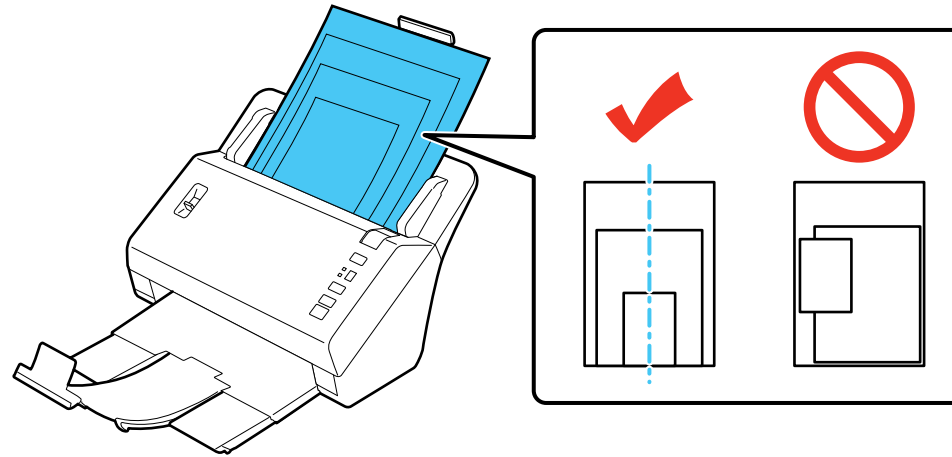

Note: If you are loading a paper business card, load it horizontally.

6. Slide the edge guides against the edges of the widest document.

Parent topic: [Loading Documents in the Input Tray](#)

Document Loading Capacity

You can load documents that meet these specifications in your scanner.

Paper size	Paper weight	Paper type	Loading capacity
Letter (8.5 × 11 inches [216 × 279 mm])	10 to 56 lb (40 to 210 g/m ²)	Plain paper Fine paper Recycled paper	10 lb (40 g/m ²): 100 sheets 21 lb (80 g/m ²): 80 sheets 56 lb (210 g/m ²): 30 sheets Loading capacity may vary depending on the paper type.
A4 (8.3 × 11.7 inches [210 × 297 mm])			
Legal (8.5 × 14 inches [216 × 356 mm])			
A5 (5.8 × 8.2 inches [148 × 210 mm])			
A6 (4.1 × 5.8 inches [105 × 148 mm])			
B5 (7.2 × 10.1 inches [182 × 257 mm])			
Business cards	Up to 56 lb (210 g/m ²)	Paper business cards	30 cards loaded horizontally

Note: You can load documents of different sizes, up to this size: Letter (8.5 × 11 inches [216 × 279 mm]). However, do not load different-sized large or thick documents, or valuable original documents or artwork.

Caution: Do not load the following types of documents in the scanner, or they may be damaged or may damage the scanner:

- Thermal paper
- Coated paper
- Documents with uneven surfaces, such as embossed documents
- Documents with wet ink
- Ripped, curled, or wrinkled documents
- Documents containing staples or paper clips
- Documents with holes, other than standard hole-punched documents
- Documents that are bound
- Documents with carbon paper backing
- Transparencies

- Glossy documents
- Carbon paper
- Non-carbon copy paper
- Perforated documents
- Documents with labels or stickers

Parent topic: [Loading Documents in the Input Tray](#)

Loading Plastic Cards in the Input Tray

You can load plastic cards that meet the card specifications in the input tray.

1. Pull up the input tray extension, extend the output tray, and flip up the stopper.

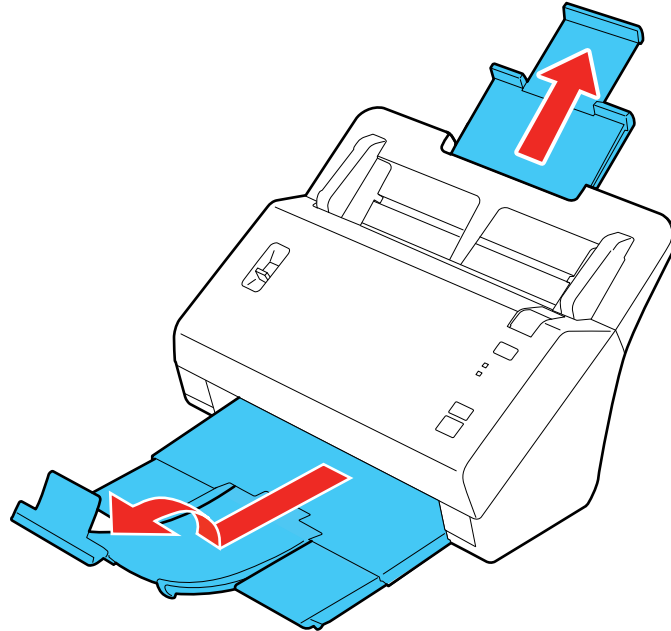

2. Slide the input tray edge guides all the way out.

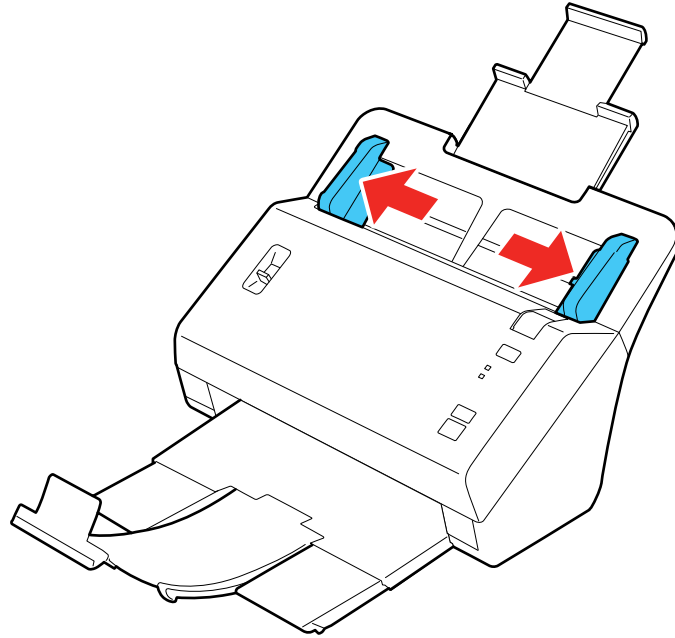

3. Load up to three standard plastic cards horizontally in the input tray as shown, sliding them in until they meet resistance. Make sure the printed side is facedown and top edge first.

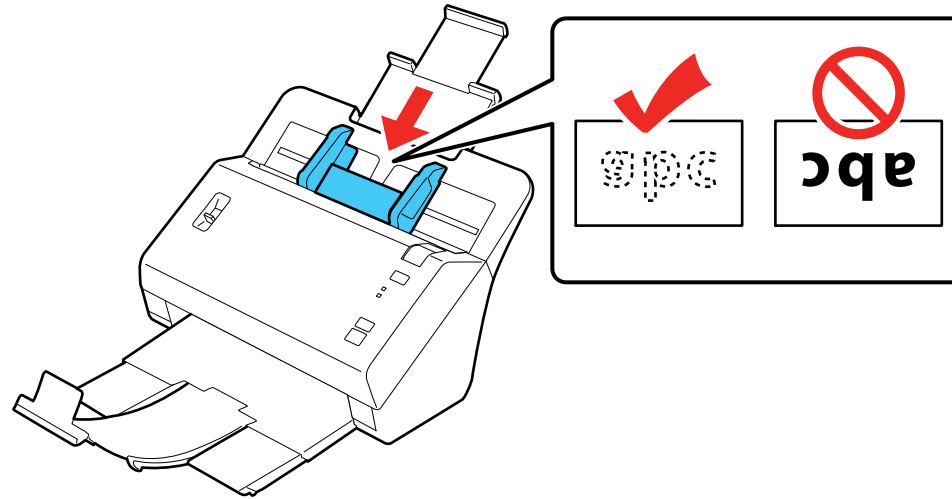

Note: You can load only one embossed plastic card at a time. Do not load plastic cards vertically.

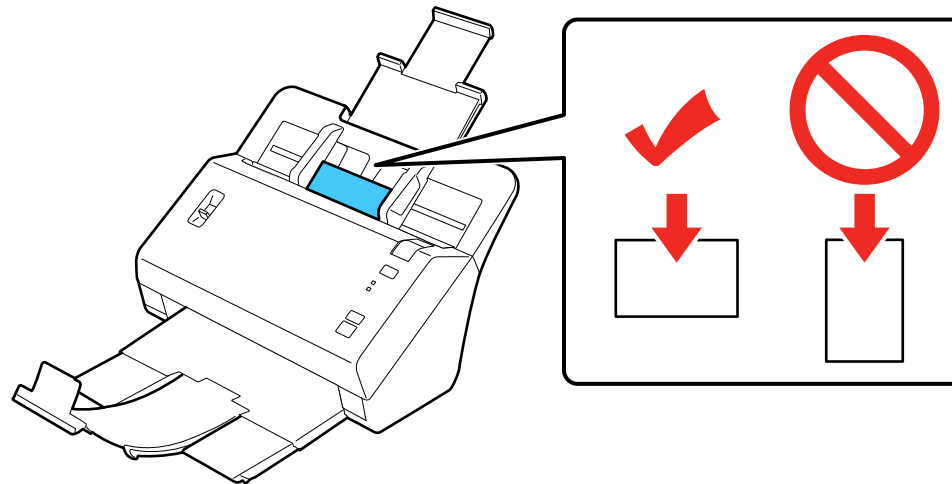

4. Slide the edge guides against the edges of the plastic card.

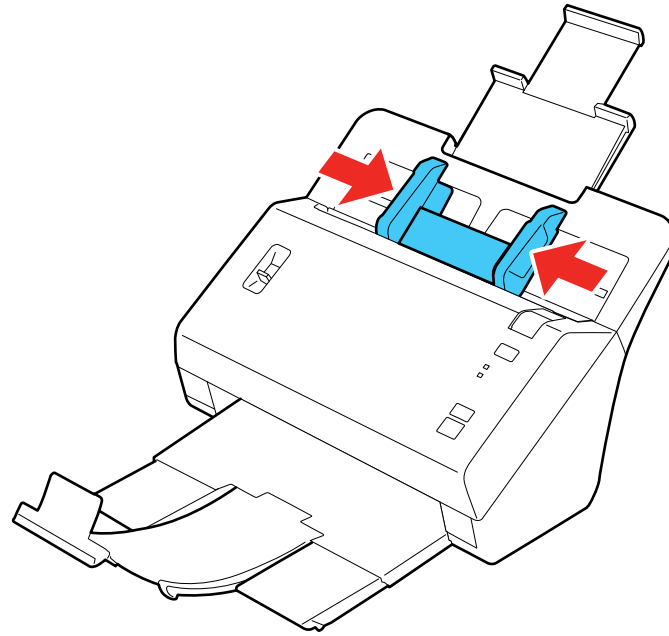

5. Set the page separation lever to the position shown here.
- When scanning a single embossed plastic card:

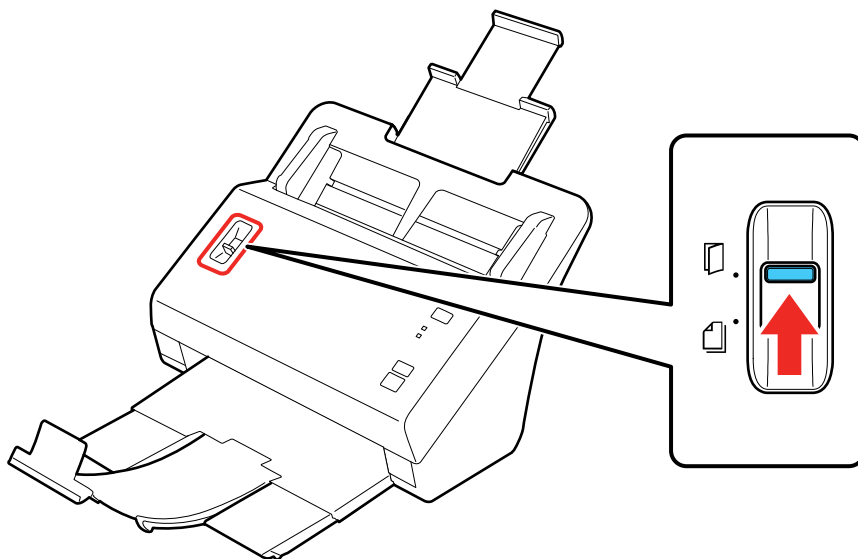

- When scanning up to 3 standard plastic cards:

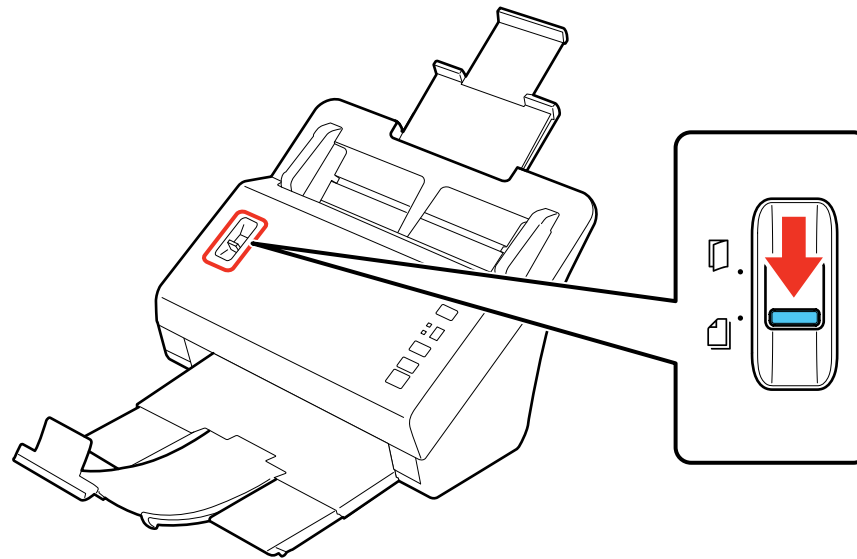

Note: To prevent paper jams, make sure to set the separation lever back to its original position when scanning standard single- or multi-page documents.

[Plastic Card Loading Capacity](#)

Parent topic: [Loading Originals](#)

Plastic Card Loading Capacity

You can load original plastic cards that meet these specifications in your scanner.

Type	Plastic cards, including embossed cards (ISO7810 compliant)
Size	2.1 × 3.3 inches (56 × 85.6 mm)
Thickness	Up to 0.05 inch (1.24 mm) thick, including any embossing
Loading capacity	Standard plastic cards: 3 Embossed plastic cards: 1
Loading direction	Horizontal (long edge first)

Note: Plastic cards with glossy surfaces may not scan properly.

Parent topic: [Loading Plastic Cards in the Input Tray](#)

Loading Special Documents

You can load a single envelope or large, thick, or folded document in the input tray. Make sure the document meets the specifications for special documents before loading it.

Note: When scanning special documents, turn off the **Detect Double Feed** setting on the Main Settings tab in Epson Scan 2. If you are scanning with the FastFoto software, close Epson Scan 2 before starting the scan.

1. Pull up the input tray extension, extend the output tray, and flip up the stopper.

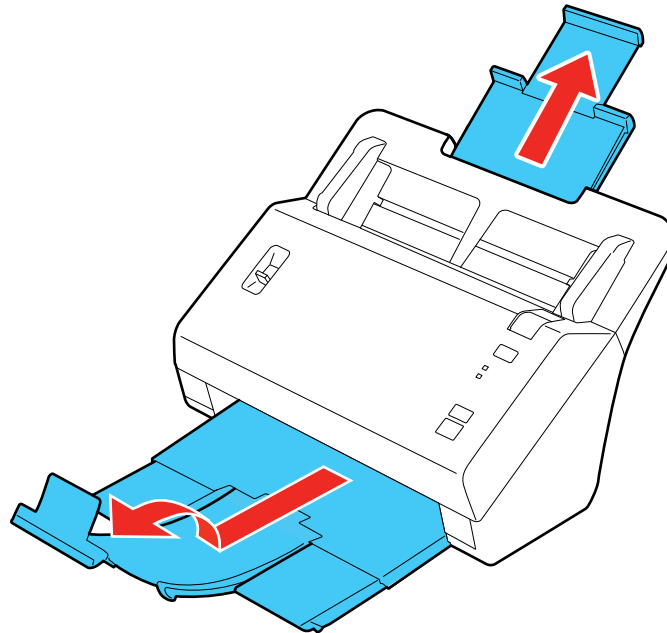

Note: If you are scanning originals longer than this, do not flip up the stopper: Letter (8.5 × 11 inches [216 × 279 mm]).

2. Slide the input tray edge guides all the way out.

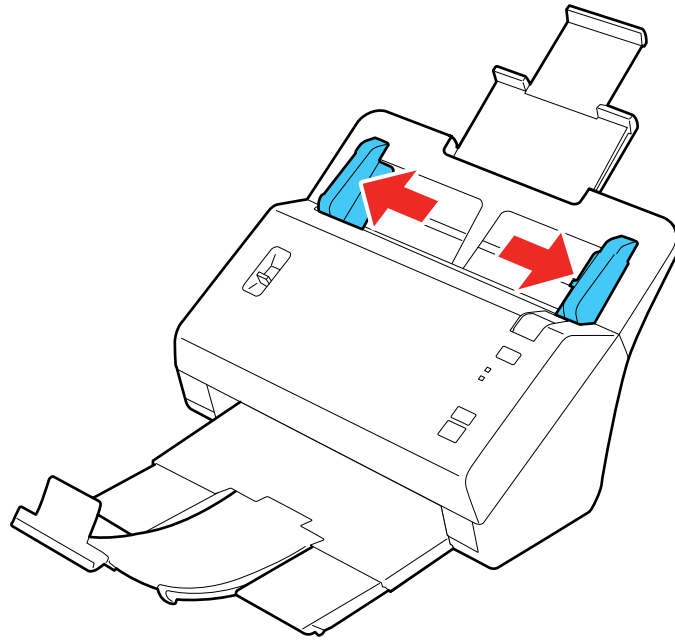

3. Do one of the following to load your original:

- Load a large or thick document, or an envelope, in the input tray as shown. Make sure the printed side is facedown and top edge first.

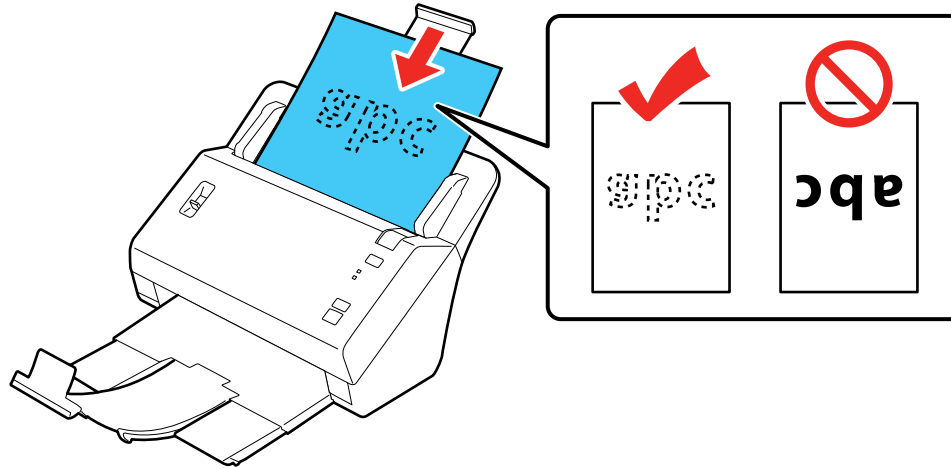

- For a folded document, fold and load the document as shown.

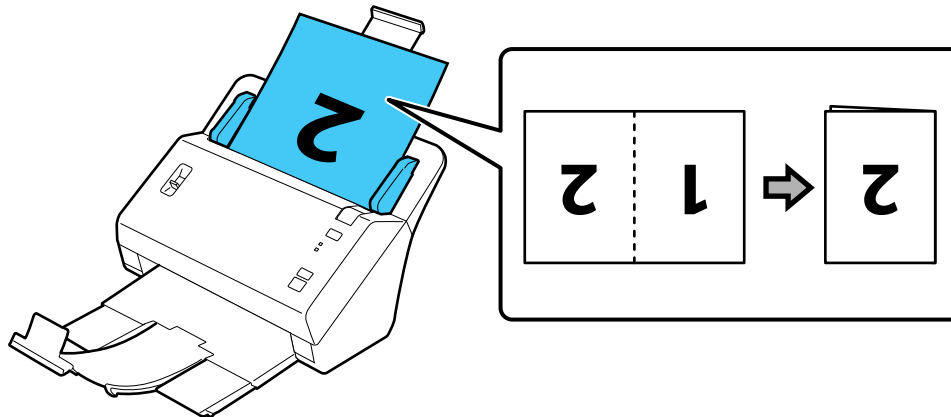

Caution: Do not load a folded document with the open side facing down.

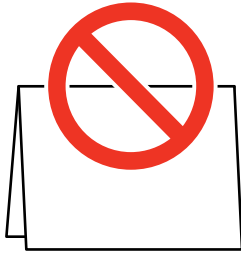

- For a photo or an irregularly-shaped document, use a carrier sheet to load the document. Do the following to load the document into the carrier sheet:
 - If the original is smaller than the carrier sheet, insert it in the center of the sheet with the printed side facedown and the top facing the arrow on the sheet.

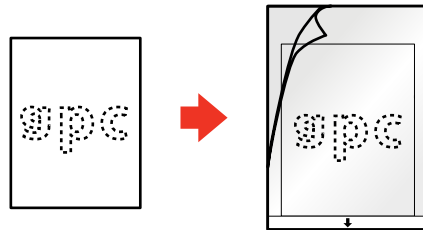

- If the original is larger than the carrier sheet, fold it in half with the sides to be scanned facing out. Position the right side of the original faceup with the top facing the arrow on the sheet.

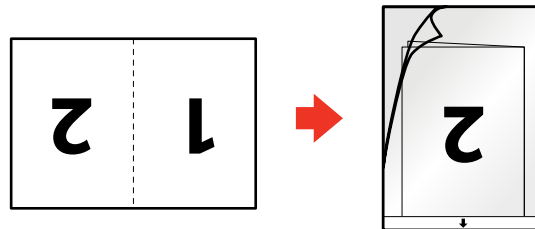

4. Slide the original into the scanner until it meets resistance.

5. Slide the edge guides against the edges of the sheet.

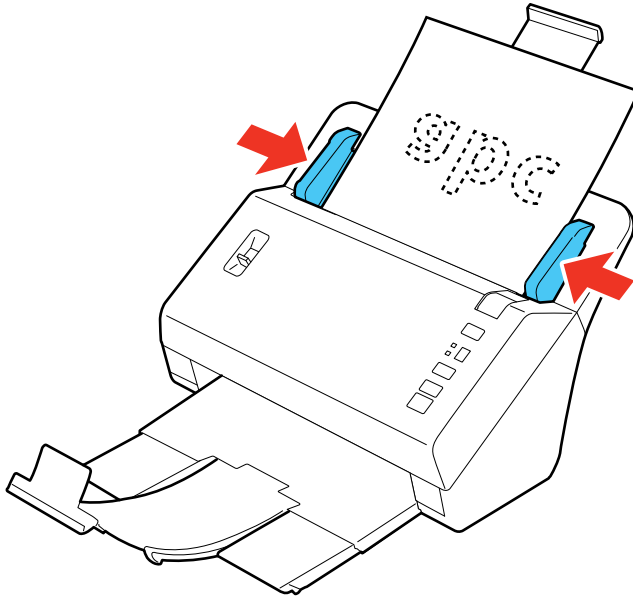

6. Set the page separation lever to the position shown here.

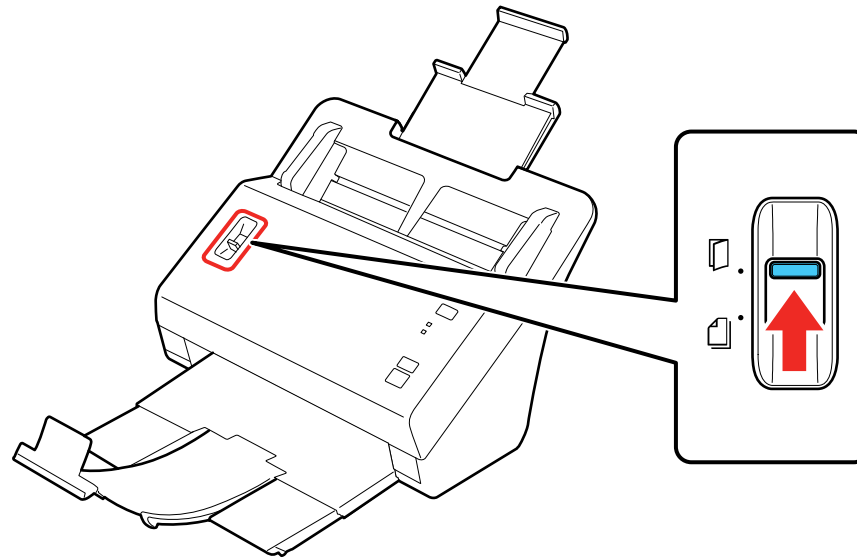

Note: To prevent paper jams, make sure to set the separation lever back to its original position when scanning standard single- or multi-page documents.

[Large or Thick Document Loading Capacity](#)

Parent topic: [Loading Originals](#)

Large or Thick Document Loading Capacity

You can load one large, thick, or folded document, or one envelope that meets these specifications in your scanner.

Paper type	Paper size	Paper weight
Plain paper, fine paper, or recycled paper	Width: 2.0 to 8.5 inches (50.8 to 215.9 mm) Length: 2.0 to 120 inches (50.8 to 3048 mm)	10 to 56 lb (40 to 210 g/m ²)

Paper type	Paper size	Paper weight
Folded plain paper, fine paper, or recycled paper	Unfolded minimum size: A6 (4.1 × 5.8 inches [105 × 148 mm]) Unfolded maximum size: A3 (11.7 × 16.5 inches [297 × 420 mm])	13 to 35 lb (50 to 130 g/m ²)
Envelope	3.6 × 6.1 inches (92 × 155 mm) to 4.7 × 10.9 inches (120 × 277 mm)	Up to 0.015 inch (0.38 mm) thick
Irregularly shaped document (load only in a carrier sheet)	Up to this size: A4 (8.3 × 11.7 inches [210 × 297 mm])	13 to 35 lb (50 to 130 g/m ²)

Parent topic: [Loading Special Documents](#)

Scanning

You can scan your originals and save them as digital files.

[Starting a Scan from a Scanner Button](#)

[Scanning Photos with Epson FastFoto](#)

[Scanning with Document Capture Pro in Standard View - Windows](#)

[Scanning with Document Capture Pro in Simple View - Windows](#)

[Scanning with Document Capture - Mac](#)

[Scanning with Epson Scan 2](#)

[Scanning Special Projects](#)

Starting a Scan from a Scanner Button

You can scan using a button on your scanner. This automatically starts the scanning program you have assigned to the button. By default, pressing the  scan button launches the FastFoto software.

Your product automatically selects suitable default scan settings, but you can view or change them as necessary.



1. Make sure you installed the scanner software and connected the scanner to your computer.
2. Load your originals in the scanner.
3. Press the  scan button.



The assigned scanning program opens on your computer.

[Changing the Default Scan Button Application](#)

Parent topic: [Scanning](#)

Changing the Default Scan Button Application

You can change the software that automatically launches when you push the  scan button on your product. By default, the Epson FastFoto software opens when you push the  scan button.

1. Do one of the following to start Epson FastFoto:
 - **Windows 10:** Click  and select **EPSON Software > Epson FastFoto**.
 - **Windows 8.x:** Navigate to the **Apps** screen and select **Epson FastFoto**.
 - **Windows (other versions):** Click  or **Start**, and select **All Programs** or **Programs**. Select **EPSON Software > Epson FastFoto**.

- **Mac:** Open the **Applications** folder and select **Epson FastFoto**.

You see a screen like this:

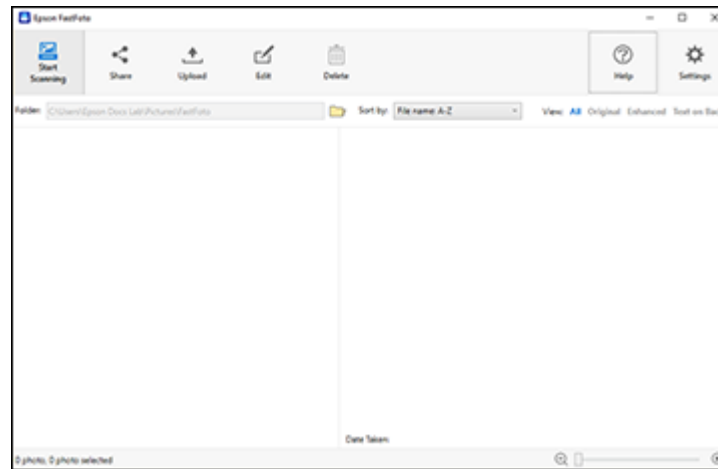

2. Click **Settings**.
3. Select the **Scanner Settings** tab.

You see a screen like this:

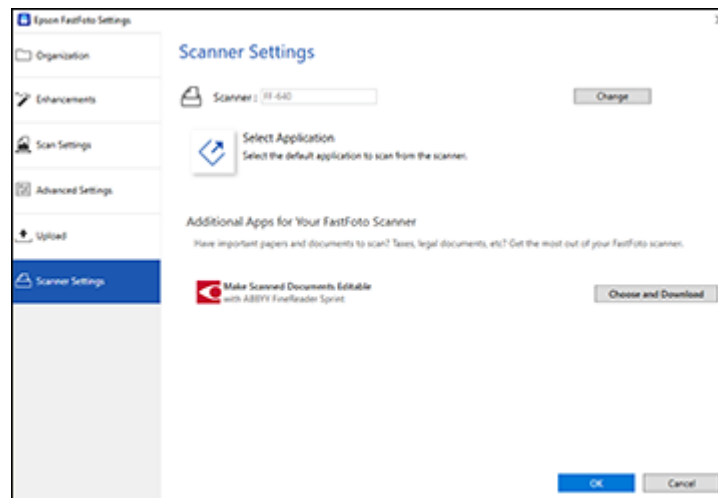

4. Click **Select Application**.

You see a screen like this:

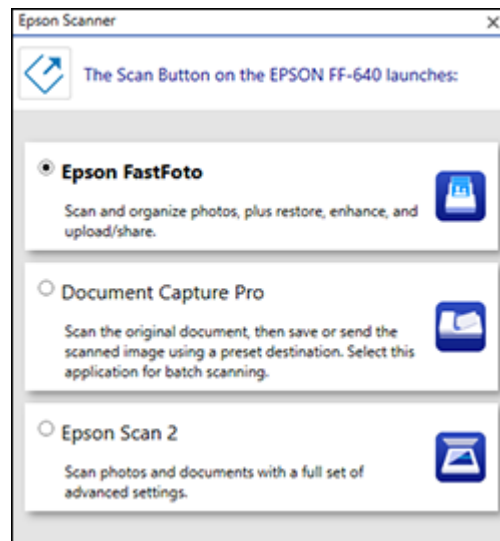

5. Choose the software you want to launch when you start a scan using the  scan button.

Parent topic: [Starting a Scan from a Scanner Button](#)

Related tasks

[Scanning Photos with Epson FastFoto](#)

[Scanning with Document Capture Pro in Standard View - Windows](#)

[Scanning with Document Capture Pro in Simple View - Windows](#)

[Scanning with Document Capture - Mac](#)

[Scanning in Epson Scan 2](#)



Scanning Photos with Epson FastFoto

When you scan photos with the Epson FastFoto software, the program automatically saves your scanned images in JPEG format on your computer in the folder you specify. You can select settings and enhancements before you scan, if necessary.

Note: This guide contains instructions for the 2.0 version of the FastFoto software. If you have an earlier version, you can download and install the latest software from the Epson support site or using the Epson Software Updater utility.

Caution: Because of the speed at which photos are scanned, dust particles on your photos can cause white lines to appear in scanned images, and in extreme cases can lightly scratch the protective finish on your photos. For best results, wipe off the front and back of your photos before scanning and use the included microfiber cloth to clean the scanner rollers after every 300 scans, or even before each scanning session. See the link below for instructions on cleaning the rollers.

Note: If you are scanning a Polaroid or other instant photo, or a panoramic photo longer than 15.5 inches (393.8 mm), make sure you select the correct photo type under **Scan Settings** in the **Settings** menu.

1. Place your photos in the input tray.
2. Do one of the following to start Epson FastFoto:
 - **Windows 10:** Click  and select **EPSON Software > Epson FastFoto**.
 - **Windows 8.x:** Navigate to the **Apps** screen and select **Epson FastFoto**.
 - **Windows (other versions):** Click  or **Start**, and select **All Programs** or **Programs**. Select **EPSON Software > Epson FastFoto**.
 - **Mac:** Open the **Applications** folder and select **Epson FastFoto**.

You see a screen like this:

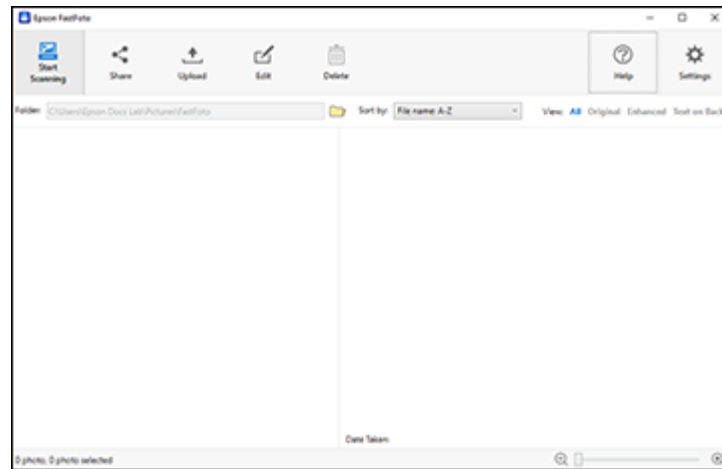

3. If you want to change any of the scanning options, click **Settings**.
 4. Click **Start Scanning**.
- You may see a screen like this:

Windows

The screenshot shows the 'Describe Your Photos' window of the EPSON FastFoto application. The window title is 'EPSON FastFoto'. Below the title bar, the text reads 'Describe Your Photos' and 'FastFoto will use this information to create organized file names, folders, and tags.' There are three input fields: 'Year' (a dropdown menu), 'Month or Season' (a dropdown menu), and 'Subject' (a text box). Below these fields, the 'File Name Preview' is shown as 'FastFoto_0001_a.jpg (default)'. A checkbox labeled 'Create a subfolder for this batch of pictures' is checked. Below it, the 'Folder Name Preview' is shown as 'C:\Users\Epson Docs Lab\Pictures\FastFoto'. At the bottom, there is an unchecked checkbox 'Do not prompt me to describe my photos when scanning' and a blue 'Start Scanning' button.

Mac

The screenshot shows the 'Describe Your Photos' window of the Epson FastFoto application on a Mac. The window title is 'Epson FastFoto'. Below the title bar, the text reads 'Describe Your Photos' and 'FastFoto will use this information to create organized file names, folders, and tags.' There are three input fields: 'Year' (a dropdown menu), 'Month or Season' (a dropdown menu), and 'Subject' (a text box). Below these fields, the 'File Name Preview' is shown as 'FastFoto_0001_a.jpg (default)'. Below this, there are two lines of text: '_a will be appended to "enhanced" file names' and '_b will be appended to "back of photo" file names'. A checkbox labeled 'Create a subfolder for this batch of pictures' is checked. Below it, the 'Folder Name Preview' is shown as '/Users/documentationlabmini/Pictures/FastFoto'. At the bottom, there is an unchecked checkbox 'Do not prompt me to describe my photos when scanning' and a 'Start Scanning' button.

5. If you want, enter a subject and date for this batch of photos. This information is added to the name of each scanned image, as shown in the preview text.
6. If you want to create a new subfolder for the scanned images, select the **Create a subfolder for this batch of pictures** checkbox.
7. If you do not want to see this window every time you scan, select the **Do not prompt me to describe my photos when scanning** checkbox.
8. Click **Start Scanning**.

The scanner scans your photos and prompts you to load more photos. When you are finished, the photos are processed and saved in the location you chose.

After you scan your photos, you can share, upload, or edit them using Epson FastFoto.

[Sharing Photos with Epson FastFoto](#)

[Uploading Photos with Epson FastFoto](#)

[Epson FastFoto Edit Menu](#)

[Available Epson FastFoto Preferences and Features](#)

Parent topic: [Scanning](#)

Related references

[Where to Get Help](#)

Related tasks

[Cleaning Inside Your Scanner](#)



[Loading Photos in the Input Tray](#)

[Changing the Default Scan Button Application](#)

[Loading Photos in the Input Tray](#)

Sharing Photos with Epson FastFoto

You can share your scanned photos via email with the Epson FastFoto software.

1. Do one of the following to start FastFoto:
 - **Windows 10:** Click  and select **EPSON Software > Epson FastFoto**.
 - **Windows 8.x:** Navigate to the **Apps** screen and select **Epson FastFoto**.
 - **Windows (other versions):** Click  or **Start**, and select **All Programs** or **Programs**. Select **EPSON Software > Epson FastFoto**.
 - **Mac:** Open the **Applications** folder and select **Epson FastFoto**.

You see a screen like this:

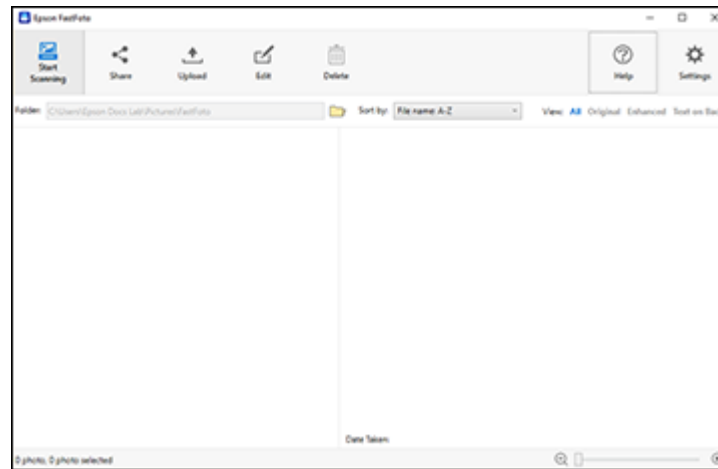

2. Click **Share**.
3. Select the scanned images you want to share.
4. Click **Email**. Enter the necessary information and click **Share**.

Note: Your email application must be previously set up and configured before you can share images. Epson FastFoto does not support web-based email, such as Gmail.

Parent topic: [Scanning Photos with Epson FastFoto](#)

Uploading Photos with Epson FastFoto

You can upload photos to Dropbox or Google Drive with the Epson FastFoto software. You can automatically upload them as you scan them, or manually upload them afterwards.

If you have not connected your Dropbox or Google Drive account with Epson FastFoto, you will be prompted to do so. To set up Dropbox, you must have Dropbox installed on your computer.

1. Do one of the following to start Epson FastFoto:
 - **Windows 10:** Click  and select **EPSON Software > Epson FastFoto**.
 - **Windows 8.x:** Navigate to the **Apps** screen and select **Epson FastFoto**.

- **Windows (other versions):** Click  or **Start**, and select **All Programs** or **Programs**. Select **EPSON Software > Epson FastFoto**.
- **Mac:** Open the **Applications** folder and select **Epson FastFoto**.

You see a window like this:

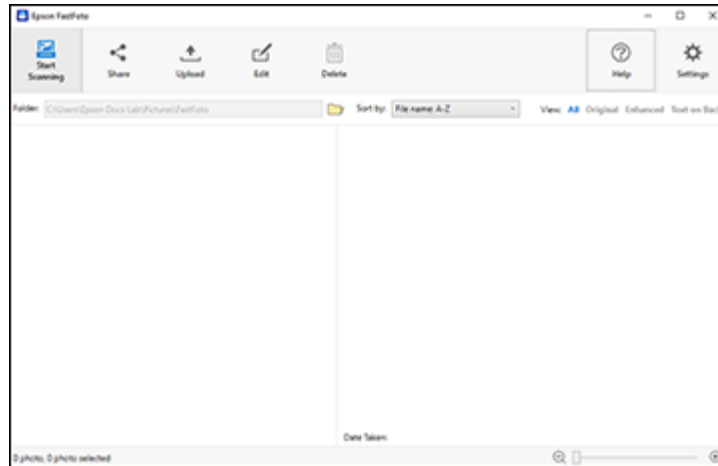

2. If you have already scanned your images, select the images you want to upload and click **Upload**.
3. Do one of the following:
 - Click **Dropbox**. Your photos are copied to your Dropbox folder.
 - Click **Google Drive**. Your photos are uploaded to Google Drive.
4. To set up automatic uploading or change your Dropbox and Google Drive settings, click **Settings**, click the **Upload** tab, and select the appropriate icon.

Parent topic: [Scanning Photos with Epson FastFoto](#)

Epson FastFoto Edit Menu

You can edit your scanned photos using these settings in the Epson FastFoto **Edit** menu.

Rotate Left

Rotates the selected photos 90° to the left. You can select and rotate multiple photos at the same time.

Rotate Right

Rotates the selected photos 90° to the right. You can select and rotate multiple photos at the same time.

Crop

Places an outline around the selected photo in the preview pane. Click and drag the outline to highlight the area you want to retain, and click **Apply** to crop the photo. (Windows only)

Enhance

Applies photo enhancement (brightness, contrast, and saturation) to all selected photos.

Restore

Applies color restoration to all selected photos.

Red Eye

Reduces the red eye effect in all selected photos.

Date

Allows you to add, edit, or remove a date from the selected photos (shown as the **Date Taken** information). (Windows only)

Undo All

Removes all edits from the selected photos made during the current session (since you started Epson FastFoto). Once you exit Epson FastFoto, your edits are permanent.

Parent topic: [Scanning Photos with Epson FastFoto](#)

Available Epson FastFoto Preferences and Features

You can select Epson FastFoto preferences and features on various tabs in the Settings window.

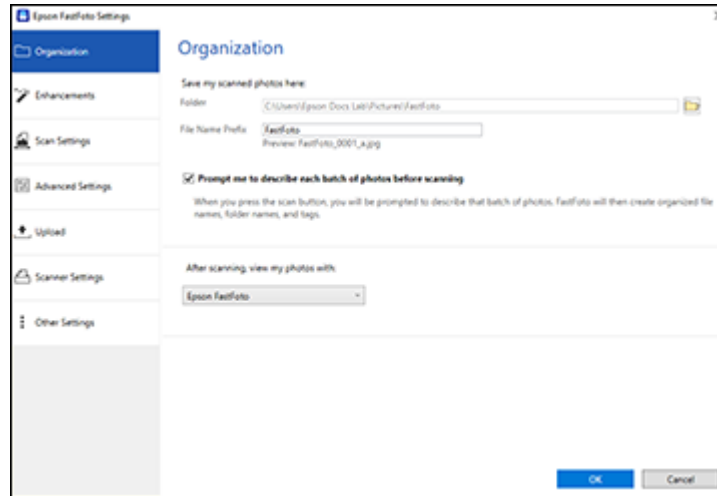

Organization tab

Save my scanned photos here

Choose a default folder in which to save your scanned photos. If you do not specify a folder during a scan, your photos will be saved to this location.

Note: On a Mac, you can choose to save your photos to the Photos application and to a folder. Select the **Save my files to Photos and to a folder** option to create an album in the Photos application in addition to saving your files in the chosen folder.

Prompt me to describe each batch of photos before scanning

Select this checkbox to be prompted during scanning to add a subject and date to your photos and create a subfolder. If you deselect the checkbox, Epson FastFoto uses the default file name prefix and folder.

After scanning, view my photos with

Choose the program from this list in which you want to view your scanned photos after scanning them with Epson FastFoto (Windows).

Enhancements tab

Auto Enhance

Automatically adjusts the brightness, contrast, and saturation of your scanned photos.

Remove Red Eye

Automatically reduces the red-eye effect in your scanned photos.

Restore Faded Colors

Restores the colors in faded photos automatically.

Apply these enhancements

Choose whether to apply the enhancements to the original scanned photos or create a separate enhanced copy with "_a" appended to the filename.

Scan Settings tab

Scan my photos at this resolution

Select the resolution at which to scan your photos. Choose 300 dpi for the fastest or general scanning, choose 600 dpi for higher resolution or archival scanning, or choose 1200 dpi for the highest resolution or enlargements.

File Format

Choose the file format in which you want to save your scans.

Scan the back of my photos with Epson single-step technology

Select whether to scan both sides of your photos when Epson FastFoto detects writing or printing on the back of them. Adjust the slider to determine the detection's sensitivity level.

Advanced Settings tab

Auto rotation

Select this checkbox to automatically rotate your scanned images.

Curled photo correction

Select this checkbox to correct edge brightness on photos that have excessive curling.

Reduce lines and streaks

Select whether to reduce the appearance of lines and streaks in your photos. Enabling this setting may slightly crop your photos.

Upload tab

Dropbox

Click to enable uploading to Dropbox.

Google Drive

Click to enable uploading to Google Drive.

Scanner Settings tab

Scanner

Select the scanner you want to use.

Select Application

Select the software application that launches when you press the  scan button on your scanner.

Choose and Download



Select to download and install any available software. (If all software is installed, this option is not available.)

Parent topic: [Scanning Photos with Epson FastFoto](#)

Scanning with Document Capture Pro in Standard View - Windows

You can use Document Capture Pro in Standard View to select settings, preview, and change the scanned file settings as necessary.

Note: The settings may vary, depending on the software version you are using. See the help information in Document Capture Pro for details.

1. Load your original in the product.
2. Do one of the following to start Document Capture Pro:
 - **Windows 10:** Click  and select **Epson Software > Document Capture Pro**.
 - **Windows 8.x:** Navigate to the **Apps** screen and select **Document Capture Pro**.
 - **Windows (other versions):** Click  or **Start**, and select **All Programs** or **Programs**. Select **Epson Software > Document Capture Pro**.

You see the Document Capture Pro window. (You may see a screen asking you to select your scanner first; if you do, select your product.)

3. If you see a **Switch to Standard View** button in the upper right corner of the window, click it.

You see a window like this:

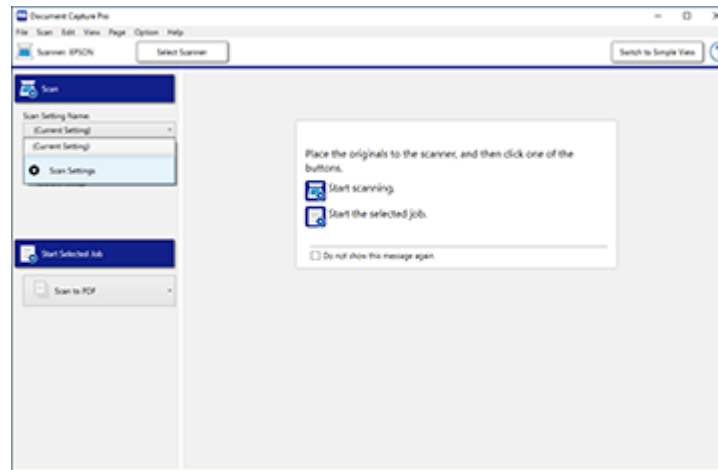

4. Select **Scan Settings** from the Scan Setting Name list (or select **Scan > Scan Settings** from the menu bar).

You see a window like this:

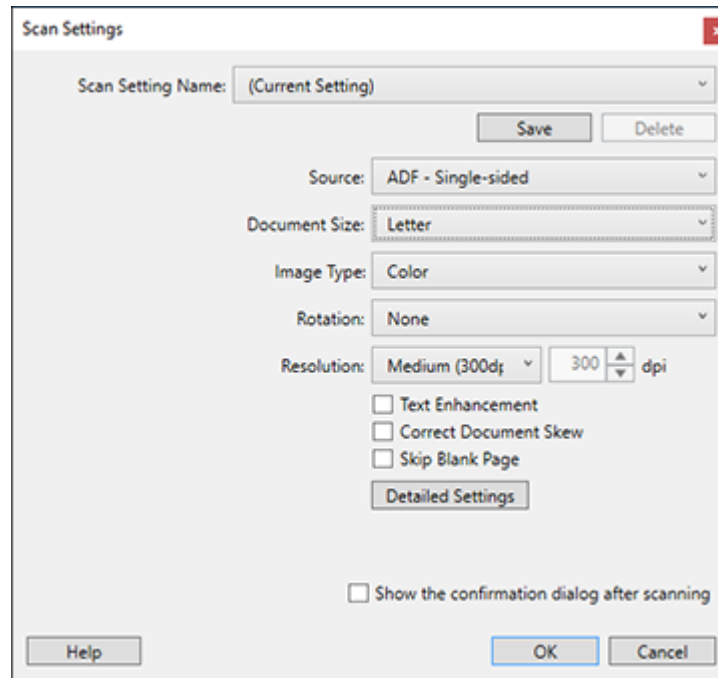

5. Select any displayed settings you want to use and click **OK**.

Note: See the help information in Document Capture Pro for details.

6. Click **Scan**.

You see a preview of your scan in the Document Capture Pro window.

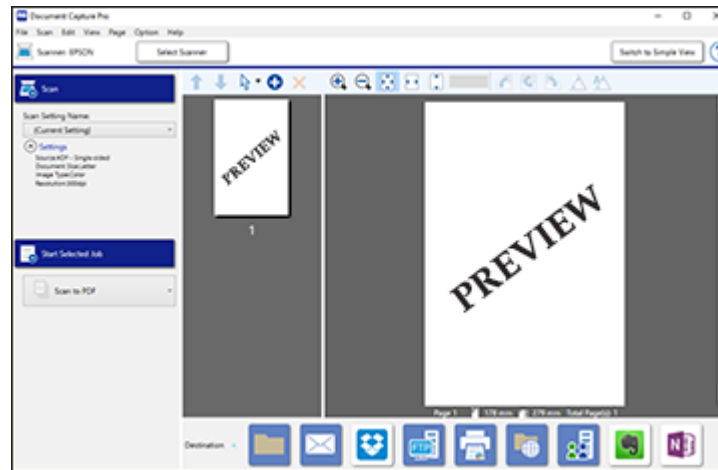

Note: You may have to close the Epson Scan 2 window to view your scan in the Document Capture Pro window.

7. If you would like to scan additional originals and add them to the current captured images, click the  Add Page(s) icon and follow the instructions on the screen.
8. Check the scanned images and edit them as necessary.

Note: See the help information in Document Capture Pro for details.

9. Click one of the Destination icons to choose where to send your scanned files. (If you cannot see all of the icons below, click the arrows next to the icons.)





10. Depending on the destination you chose, click **OK** or **Send** to complete the scan.

Parent topic: [Scanning](#)

Scanning with Document Capture Pro in Simple View - Windows

You can use Document Capture Pro in Simple View to quickly select options and scan.

Note: The settings may vary, depending on the software version you are using. See the help information in Document Capture Pro for details.

1. Load your original in the product.
2. Do one of the following to start Document Capture Pro:
 - **Windows 10:** Click  and select **Epson Software > Document Capture Pro**.
 - **Windows 8.x:** Navigate to the **Apps** screen and select **Document Capture Pro**.
 - **Windows (other versions):** Click  or **Start**, and select **All Programs** or **Programs**. Select **Epson Software > Document Capture Pro**.

You see the Document Capture Pro window. (You may see a screen asking you to select your scanner first; if you do, select your product.)

3. If you see a **Switch to Simple View** button in the upper right corner of the window, click it.

You see a window like this:

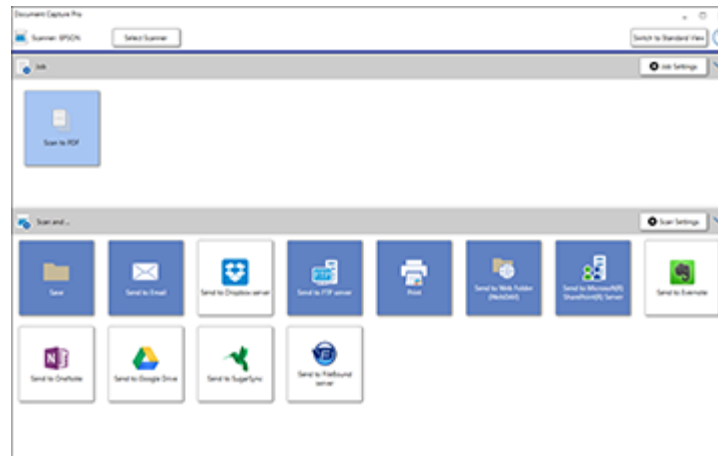

4. Click **Select Scanner** and select your scanner from the scanner list, if necessary.

5. If you want to use a scan job, click one of the job icons in the **Job** section of the window to complete and send your scan with one click.

Note: If you do not see any icons, click the **V** symbol next to the **Job Settings** button.

6. If you want to select scan settings for a particular destination, click the **Scan Settings** button, select any displayed settings you want to use, and click **OK**.

Note: See the help information in Document Capture Pro for details. If you do not see the **Scan Settings** button, click the **<** symbol in the **Scan and...** bar.

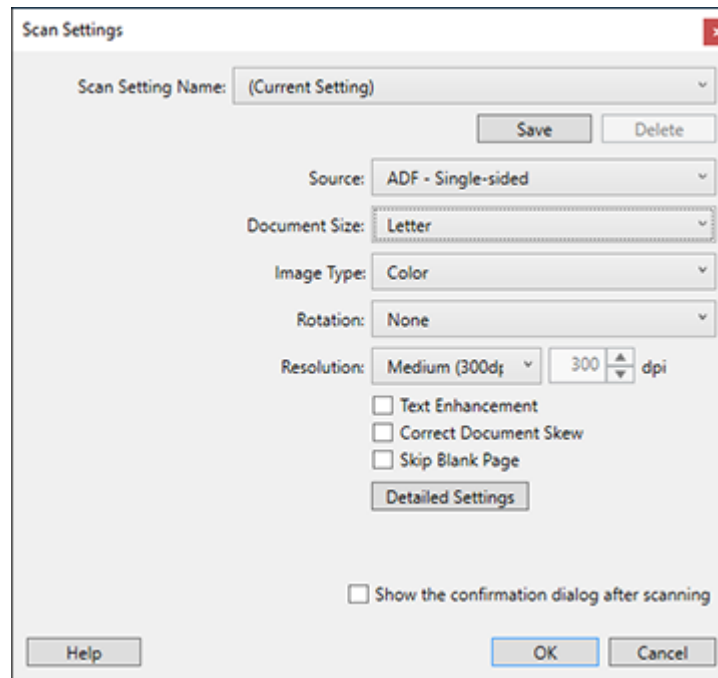

7. Click one of the destination icons in the **Scan and...** section of the window. Your product starts scanning and you see the settings window.
8. Select any destination settings as necessary and click **OK**.

Note: See the help information in Document Capture Pro for details.

9. Confirm your settings and click **OK** or **Close**.

Parent topic: [Scanning](#)

Scanning with Document Capture - Mac

When you scan with Document Capture, the program automatically saves your scanned file on your computer in the folder you specify. You can select settings, preview, and change the scanned file settings as necessary.

Note: The settings may vary, depending on the software version you are using. See the Help information in Document Capture for details.

1. Load your original in the product.
2. Open the **Applications** folder, open the **Epson Software** folder, and select **Document Capture**.

You see a window like this:

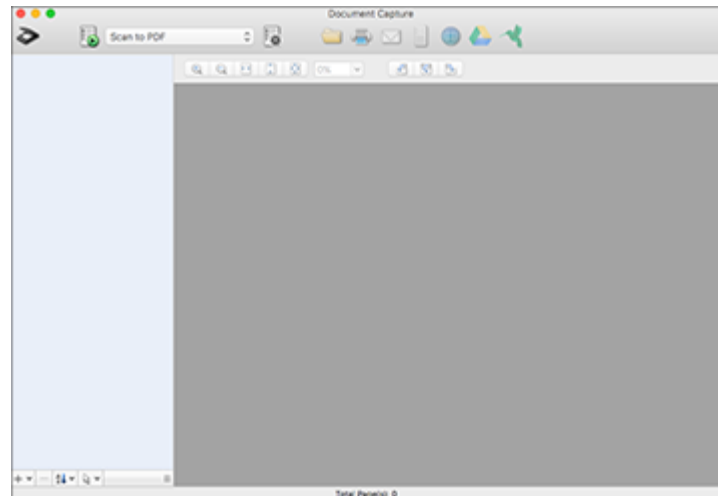

Note: You may need to select your scanner from the scanner list.

3. Click the  **Scan** icon.

You see a window like this:

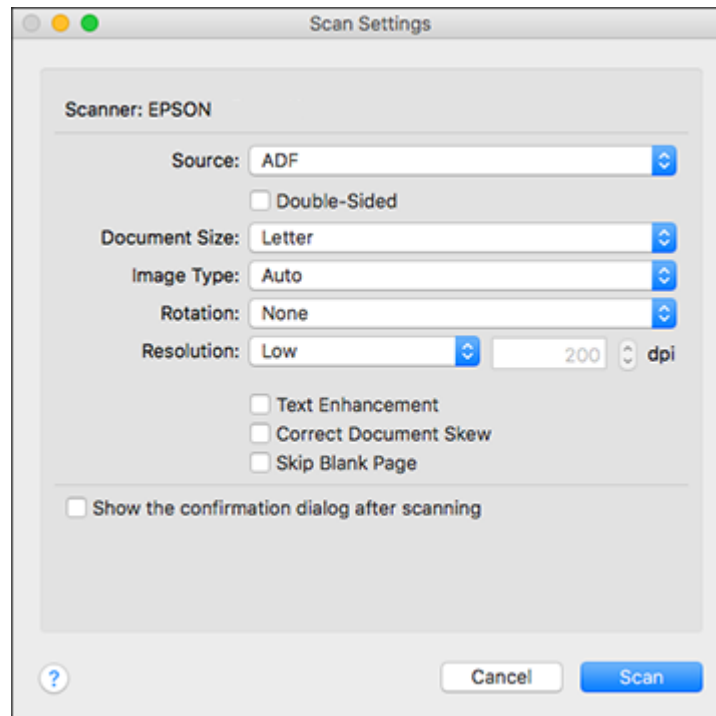

Note: If you want to use a scan job that you created instead, select it from the Job list in the Document Capture window, click the  Start Job button, and skip the rest of these steps.

4. Select any displayed scan settings you want to use.

Note: See the Help information in Document Capture for details.

5. If you want to select detailed scan settings, close the Scan Settings window, open the **Scan** menu at the top of the Mac desktop, and select **Displays the EPSON Scan Setup Screen**.
6. Click the  Scan icon and select any detailed scan settings you want to use from the Epson Scan 2 window.
7. Click **Scan**.

You see a preview of your scan in the Document Capture window.

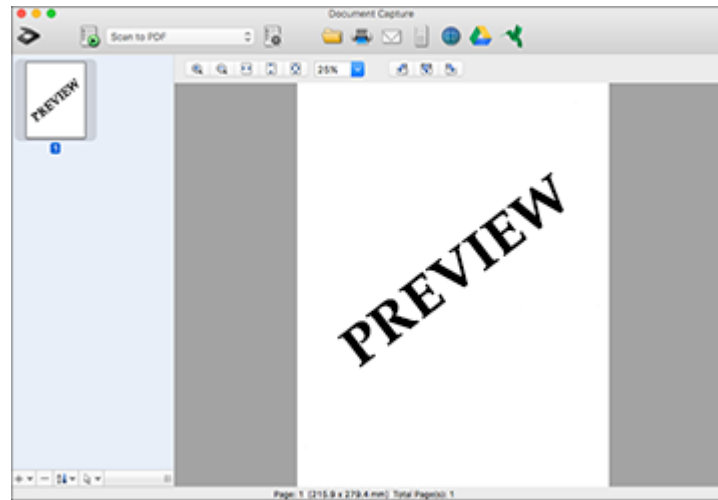

Note: You may have to close the Epson Scan 2 window to view your scan in the Document Capture window.

8. If you would like to scan additional originals and add them to the current captured images, click the + icon, select **Acquire from Scanner**, and repeat the previous steps.
9. Check the scanned images and edit them as necessary.
10. Click one of the Destination icons to choose where to send your scanned files. (If you cannot see all of the icons below, click the arrow next to the icons.)



11. Depending on the destination you chose, click **OK** or **Send** to complete the operation.

Parent topic: [Scanning](#)

Scanning with Epson Scan 2

After placing your original documents or photos on your product for scanning, you can scan them using Epson Scan 2.

[Starting a Scan Using the Epson Scan 2 Icon](#)

[Starting a Scan from a Scanning Program](#)



[Scanning in Epson Scan 2](#)

Parent topic: [Scanning](#)

Starting a Scan Using the Epson Scan 2 Icon

You can start the Epson Scan 2 program to select scan settings, scan, and save the scanned image to a file.

Note: If you are using your Epson product with the Windows 10 S operating system, you cannot use the software described in this section. You also cannot download and install any Epson product software from the Epson website for use with Windows 10 S; you must obtain software only from the Windows Store.

- **Windows 10:** Click  and select **EPSON > Epson Scan 2**.
- **Windows 8.x:** Navigate to the **Apps** screen and select **Epson Scan 2**.
- **Windows (other versions):** Click  or **Start**, and select **All Programs** or **Programs**. Select **EPSON > Epson Scan 2 > Epson Scan 2**.
- **Mac:** Open the **Applications** folder, open the **Epson Software** folder, and select **Epson Scan 2**.

You see an Epson Scan 2 window like this:

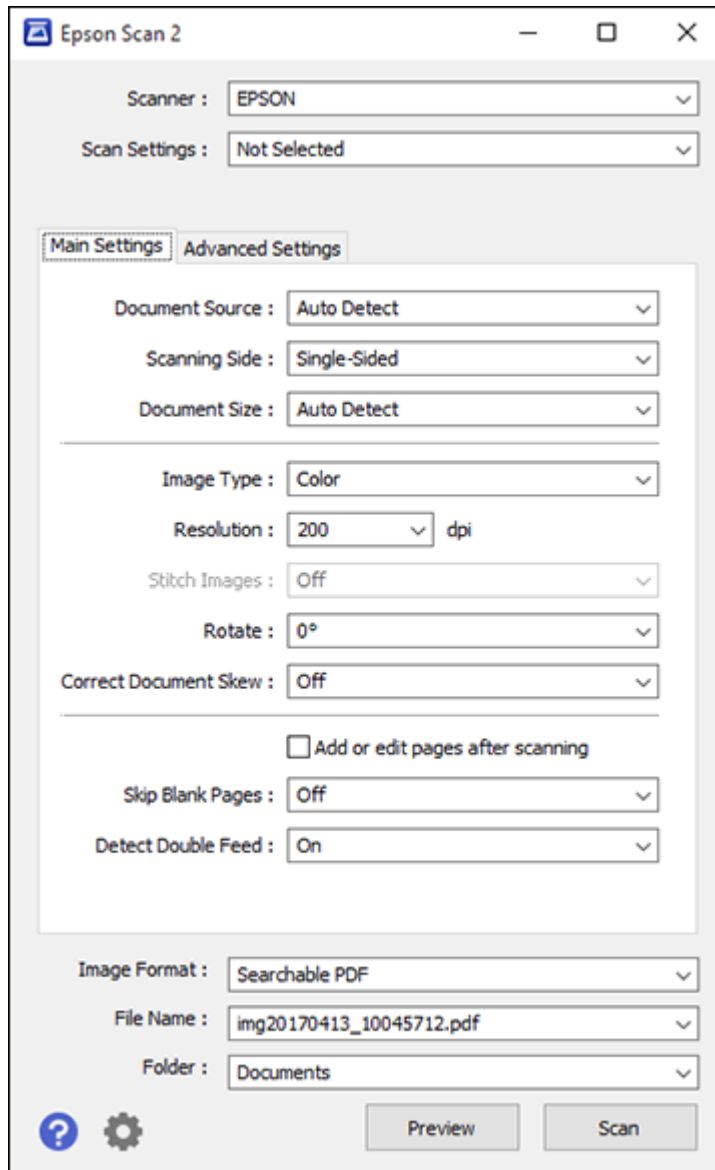

Parent topic: [Scanning with Epson Scan 2](#)

Starting a Scan from a Scanning Program

You can start Epson Scan 2 from a TWAIN-compliant scanning program to select scan settings, scan, and open the scanned image in the program.

Note: If you are using your Epson product with the Windows 10 S operating system, you cannot use the software described in this section. You also cannot download and install any Epson product software from the Epson website for use with Windows 10 S; you must obtain software only from the Windows Store.

1. Open your scanning program and select its scanning option. (See your scanning program help for instructions.)
2. Select your product.

Note: In certain programs, you may need to select your product as the "source" first. If you see a **Select Source** option, choose it and select your product. With Windows, do not select a **WIA** option for your product; not all scan functions will be available.

You see an Epson Scan 2 window like this:

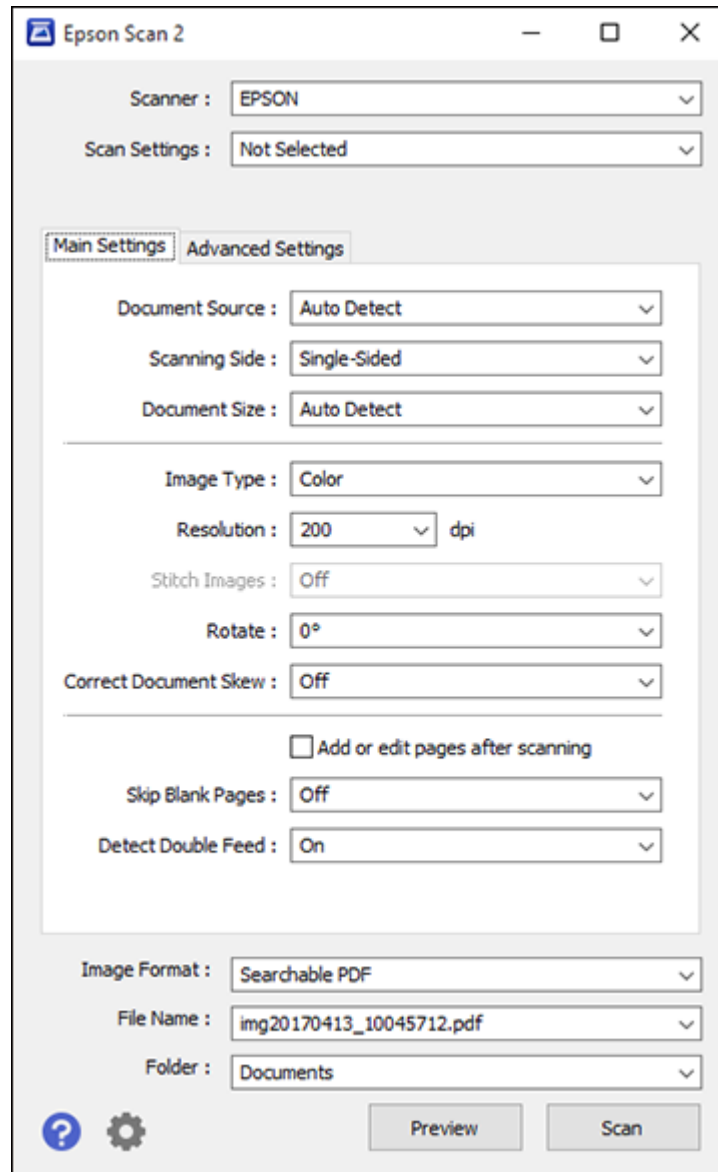

Parent topic: [Scanning with Epson Scan 2](#)

Scanning in Epson Scan 2

Epson Scan 2 automatically scans your document and saves the scanned file in JPEG format in your operating system's Documents or My Documents folder, or opens it in your scanning program. You can select settings, preview, and change the scanned file settings as necessary.

1. Load your original in the product.
2. Start Epson Scan 2.

You see this window:

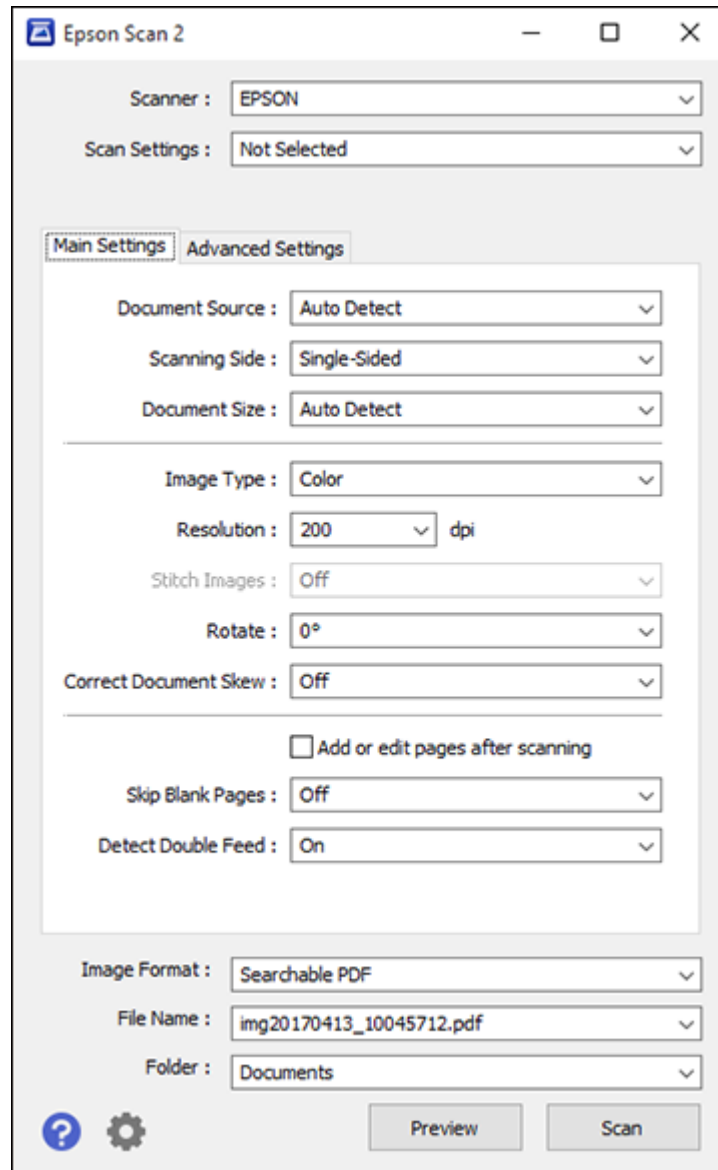

3. If you are using a carrier sheet to scan your original, select **Carrier Sheet** as the **Document Source** setting.

Note: The **Document Source** setting is automatically set to **ADF** for your product.

4. Select the **Scanning Side** setting that matches the sides of the original that you want to scan.
5. Select the **Document Size** setting that matches the size of your original, or select **Auto Detect** to have Epson Scan 2 automatically detect the size. You can select **Customize** to enter a custom size, if necessary.
6. Select your original image type and how you want it scanned as the **Image Type** setting.
7. Select the **Resolution** setting you want to use for your scan.
8. Select any of the additional settings that you want to use on the **Main Settings** tab.
9. Click the **Advanced Settings** tab and select any settings that you want to use.
10. To see a preview of your scan with the settings you selected, click the **Preview** button.

Epson Scan 2 previews your original and displays the results in the Epson Scan 2 window.

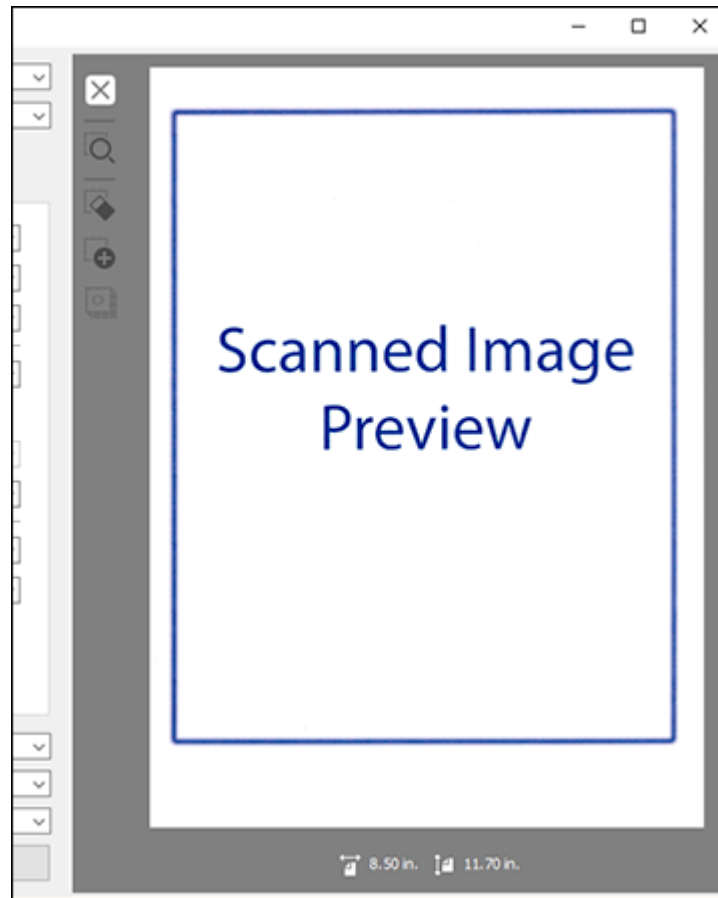

11. Reinsert your original into the ADF.
12. Select the format in which you want to save your scanned file as the **Image Format** setting. If necessary, select **Options** and select any desired format options.
13. Enter the file name for your scanned file in the **File Name** field. Select **Settings** to modify the file name settings.
14. Select the location in which you want to save your scanned file as the **Folder** setting. If necessary, select **Select** to create a new folder.

15. Click **Scan**.

The product scans your original and saves the scanned file in the location you specified.

[Additional Scanning Settings - Main Settings Tab](#)

[Additional Scanning Settings - Advanced Settings Tab](#)

[Image Format Options](#)

[Scan Resolution Guidelines](#)

Parent topic: [Scanning with Epson Scan 2](#)

Related tasks

[Loading Photos in the Input Tray](#)

[Loading Documents in the Input Tray](#)

[Loading Plastic Cards in the Input Tray](#)

[Loading Special Documents](#)

[Cleaning Inside Your Scanner](#)

Additional Scanning Settings - Main Settings Tab

You can select these additional scanning settings on the Epson Scan 2 Main Settings tab.

Stitch Images

When scanning double-sided originals, lets you lay out images from both sides of the original onto one scanned page.

Rotate

Rotates the original image clockwise to the desired angle before scanning it. Select **Auto** to allow your product to automatically rotate the image based on the orientation of the text (may take longer to scan).

Correct Document Skew

Corrects skewed originals, image contents, or both.

Add or edit pages after scanning

Lets you add, remove, or edit the pages in a scan, including rotating pages and changing the page order.

Note: To save multiple pages in a single file, you must select a file format that supports multiple pages such as **PDF** or **Multi-TIFF**. If you select another file format, each scanned image or page is saved as a separate file.

Skip Blank Pages

If the scanner detects marks from the other side of a blank page and adds the marks to the scanned image, adjust this setting to prevent this.

Detect Double Feed

Detects a double-feed paper error in the ADF. If you are scanning an original envelope or plastic card, select **Off**.

Parent topic: [Scanning in Epson Scan 2](#)

Additional Scanning Settings - Advanced Settings Tab

You can select these additional scanning settings on the Epson Scan 2 Advanced Settings tab. Not all adjustment settings may be available, depending on other settings you have chosen.

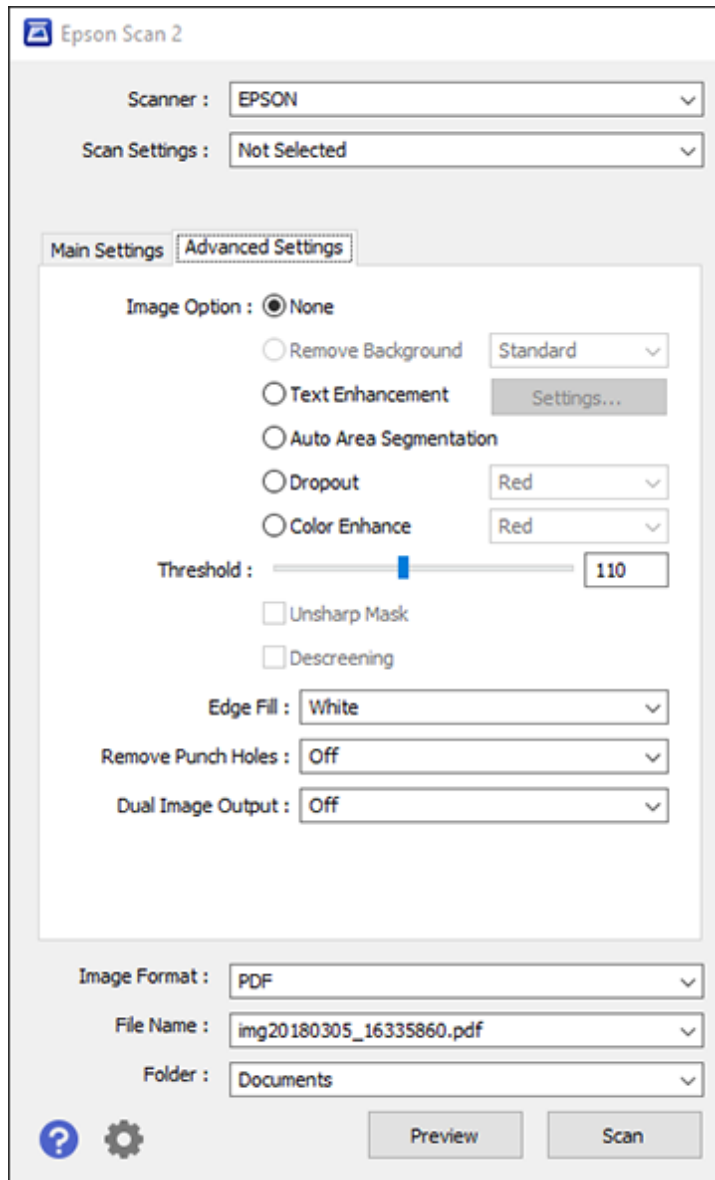

The screenshot shows the 'Epson Scan 2' application window with the 'Advanced Settings' tab selected. At the top, 'Scanner' is set to 'EPSON' and 'Scan Settings' is 'Not Selected'. The 'Advanced Settings' section includes:

- Image Option:** None, Remove Background (Standard), Text Enhancement (Settings...), Auto Area Segmentation, Dropout (Red), Color Enhance (Red).
- Threshold:** A slider set to 110.
- Unsharp Mask
- Descreening
- Edge Fill:** White
- Remove Punch Holes:** Off
- Dual Image Output:** Off

At the bottom, 'Image Format' is PDF, 'File Name' is 'img20180305_16335860.pdf', and 'Folder' is 'Documents'. There are also 'Preview' and 'Scan' buttons, along with help and settings icons.

Text Enhancement

Sharpens the appearance of letters in text documents.

Auto Area Segmentation

Makes black and white images clearer and text recognition more accurate by separating the text from the graphics.

Dropout

The scan will not pick up the color you select. This setting is available only if you select **Grayscale** or **Black & White** as the Image Type setting.

Color Enhance

Enhances the shades of the color you select in the scanned image. This setting is available only if you select **Grayscale** or **Black & White** as the Image Type setting.

Brightness

Adjusts the overall lightness and darkness of the scanned image.

Contrast

Adjusts the difference between the light and dark areas of the overall scanned image.

Gamma

Adjusts the midtone density of the scanned image.

Threshold

Adjusts the level at which black areas in text and line art are delineated, improving text recognition in OCR (Optical Character Recognition) programs.

Unsharp Mask

Makes the edges of certain image areas clearer. Turn off this option to leave softer edges.

Descreening

Removes the ripple pattern that might appear in subtly shaded image areas, such as skin tones. This option improves results when scanning magazines or newspapers. (The results of descreening do not appear in the preview image, only in your scanned image.)

Edge Fill

Corrects shadowing around the edges of the image by filling the shadows with black or white.

Remove Punch Holes

Removes the shadows caused by holes on the edges of the original.

Dual Image Output

Scans the original image twice using different output settings (Windows only).

Parent topic: [Scanning in Epson Scan 2](#)

Image Format Options

You can select different image formats and related options. For details on available options, click the ? icon on the Epson Scan 2 Image Format Options window. Not all image formats have options.

Bitmap (*.bmp)

A standard image file format for most Windows programs.

JPEG (*.jpg)

An image format that lets you highly compress image data. However, the higher the compression, the lower the image quality. (The TIFF format is recommended when you need to modify or retouch your scanned image.)

PNG (*.png)

An image format that does not lose quality during editing.

TIFF (*.tif)

A file format created for exchanging data between many programs, such as graphic and DTP software.

Multi-TIFF (*.tif)

A TIFF file format when multiple pages are saved to the same file, allowing you to edit the images using a compatible program.

PDF (*.pdf)

A document format that is readable by Windows and Mac systems using Adobe Reader, Acrobat, or other programs. You can save multi-page documents in one PDF file.

Searchable PDF (*.pdf)

A document format that is readable by Windows and Mac systems using Adobe Reader, Acrobat, or other programs. You can save multi-page documents in one PDF file. Recognized text in the scanned document can be searched.

Parent topic: [Scanning in Epson Scan 2](#)

Scan Resolution Guidelines

The resolution setting in your scanning software, measured in dpi (dots per inch), controls the amount of detail captured in your scans. Increasing the resolution raises the amount of detailed captured but comes with the following disadvantages:

- Larger file sizes
- It takes longer to scan your originals, send/receive your scans by email or fax, and to print your scans
- The image may become too large to fit on your display or print on paper

If you plan to enlarge a scanned image so you can print it at a larger size, you may need to increase the resolution from the default resolution set by the software. Follow these guidelines to determine the resolution setting you need:

- You will scan the image at its original size but enlarge it later in an image-editing program.
Increase the resolution setting in your scanning software. Increase the resolution by the same amount you will increase the image size to retain a high image quality. For example, if the resolution is 300 dpi (dots per inch) and you will double the image size later, change the resolution setting to 600 dpi.
- You will scan the image at 100% or smaller size.
Select the resolution setting based on how you will use the scanned image:
 - Email/view on a computer screen/post on the web: 96 to 200 dpi
 - Print/fax/convert to editable text (OCR)/create searchable PDF: 200 to 300 dpi

Parent topic: [Scanning in Epson Scan 2](#)

Scanning Special Projects

Your product's scanning software offers various options to help you quickly complete special scan projects.

[Scanning Two Originals onto One Sheet \(Stitching Images\) - Windows](#)

[Scanning Multi-Page Originals as Separate Files - Windows](#)

[Saving Scanned Documents as a Searchable PDF Using Epson Scan 2](#)

[Saving Scanned Documents as a Searchable PDF with Document Capture - Mac](#)

[Saving a Scan as an Office Format File - Windows](#)

[Saving a Scan as an Office Format File - Mac](#)

[Convert Scanned Documents to Editable Text \(OCR\)](#)



[Scanning to a SharePoint Server or Cloud Service - Windows](#)

Parent topic: [Scanning](#)

Scanning Two Originals onto One Sheet (Stitching Images) - Windows

You can scan both sides of a double-sided or folded original and combine them into a single image with the Epson Scan 2 Stitch Images settings (not available for all products).

Note: The settings may vary, depending on the software version you are using. See the help information in Document Capture Pro for details.

1. Load your original in the product.
2. Do one of the following to start Document Capture Pro:
 - **Windows 10:** Click  and select **Epson Software > Document Capture Pro**.
 - **Windows 8.x:** Navigate to the **Apps** screen and select **Document Capture Pro**.
 - **Windows (other versions):** Click  or **Start** and select **All Programs** or **Programs**. Select **Epson Software > Document Capture Pro**.
3. If you see a **Switch to Simple View** button in the upper right corner of the window, click it.
You see a window like this:

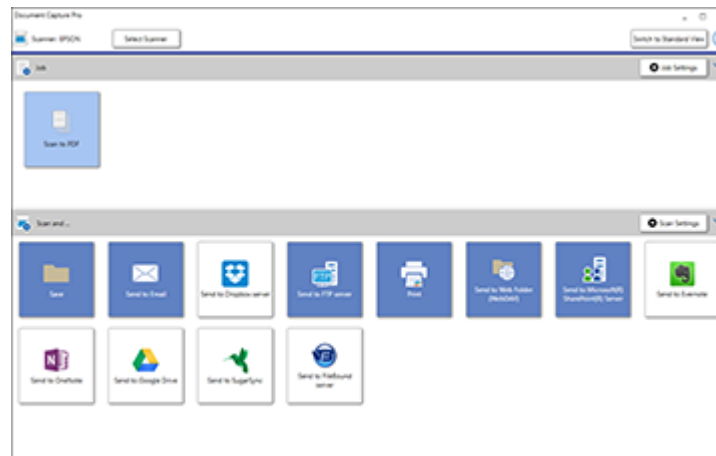

4. Click the **Scan Settings** button, then click **Detailed Settings**.

Note: If you do not see any icons, click the **V** symbol next to the **Job Settings** button.

You see an Epson Scan 2 window like this:

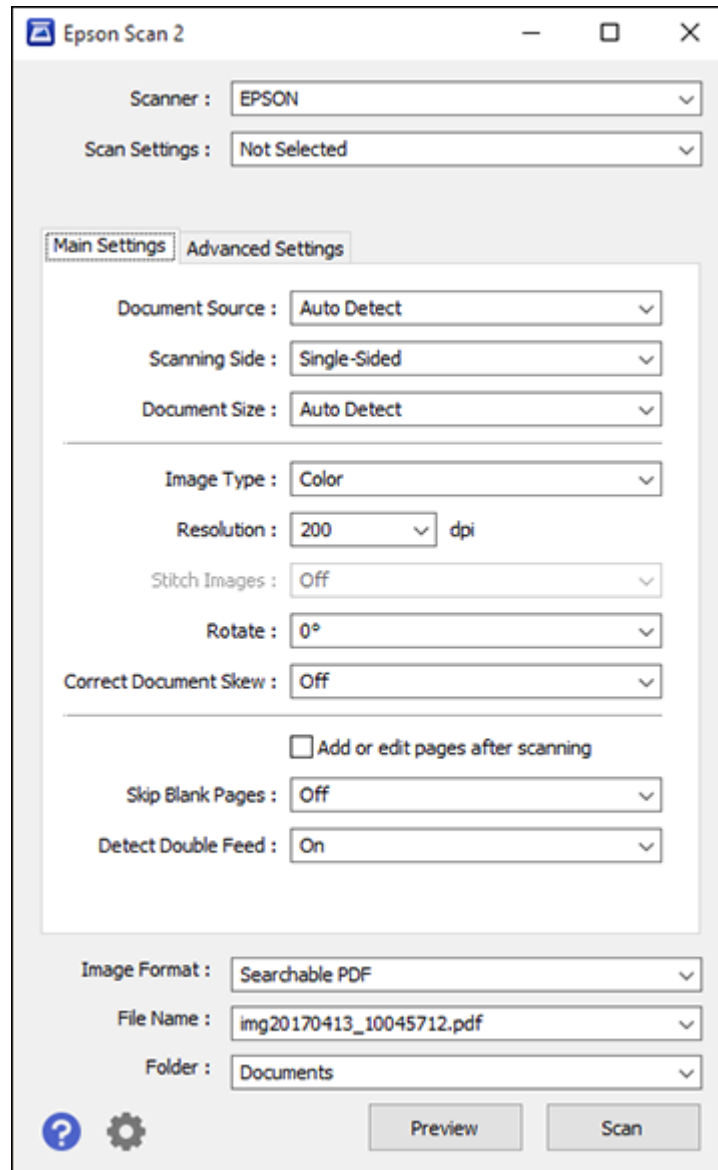

5. Select **Double-Sided** as the **Scanning Side** setting.
6. Select the original document size or **Auto Detect** as the **Document Size** setting.
7. Select one of the following as the **Stitch Images** setting:
 - **Top&Bottom**: Places the scanned images one above the other.
 - **Left&Right**: Places the scanned images side by side.
8. Select the **Advanced Settings** tab and set the **Edge Fill** setting to **None**.
9. Click **Save**.
10. Click **OK**.
11. Click **Scan**.

The scanned image is displayed.

Note: If the scanned images are not stitched together in the correct orientation, click **Scanning Side** on the Epson Scan 2 window, select **Settings**, set the Binding Edge to **Left** or **Top**, and rescan the document.

Parent topic: [Scanning Special Projects](#)

Related tasks

[Loading Photos in the Input Tray](#)

[Loading Documents in the Input Tray](#)

[Loading Plastic Cards in the Input Tray](#)



[Loading Special Documents](#)

Scanning Multi-Page Originals as Separate Files - Windows

You can use Document Capture Pro (Windows) to scan multi-page originals as separate scanned files. You indicate how the separate files are created by defining a maximum page count per file or by inserting blank pages, barcodes, or characters that can be detected by the software as separation markers.

Note: The settings may vary, depending on the software version you are using. See the help information in Document Capture Pro for details.

1. Load your multi-page original in the product.

2. Do one of the following to start Document Capture Pro:
 - **Windows 10:** Click  and select **Epson Software > Document Capture Pro**.
 - **Windows 8.x:** Navigate to the **Apps** screen and select **Document Capture Pro**.
 - **Windows (other versions):** Click  or **Start**, and select **All Programs** or **Programs**. Select **Epson Software > Document Capture Pro**.

You see the Document Capture Pro window.

3. If you see a **Switch to Simple View** button in the upper right corner of the window, click it.

You see a window like this:

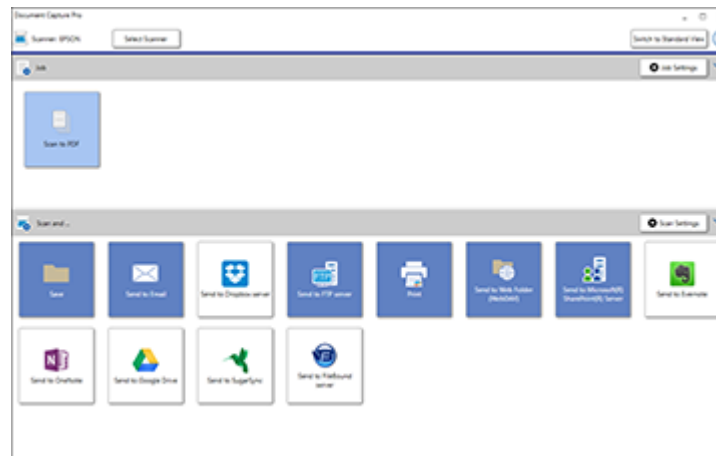

4. Click the **Scan Settings** button.

Note: If you do not see any icons, click the **V** symbol next to the **Job Settings** button.

You see a window like this:

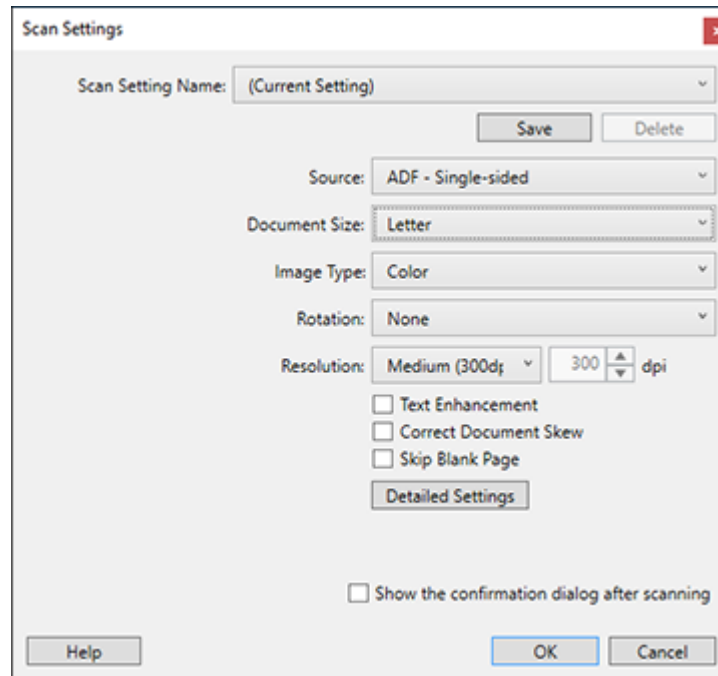

5. Select any displayed settings you want to use and click **OK**.

Note: See the help information in Document Capture Pro for details.

6. Click one of the destination icons (except **Print**) in the **Scan and...** section of the window. Your product starts scanning and you see the settings window.
7. Select the **Apply job separation** checkbox.
8. Click **Separation Settings**.

You see a window like this:

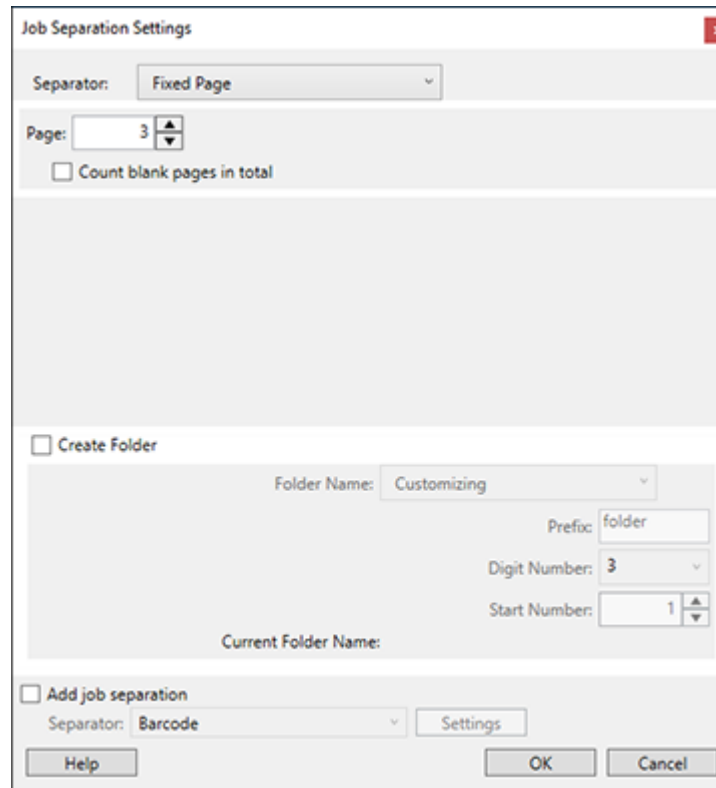

9. Select the method you used to separate the originals as the **Separator** setting.

Note: See the help information in Document Capture Pro for details.

10. If necessary, select **Create Folder** and select a folder name.
11. Select any other folder naming settings you want and click **OK**, then click **OK** again.

Your originals are saved into separate files and folders as specified.

Parent topic: [Scanning Special Projects](#)

Related tasks

[Loading Documents in the Input Tray](#)

[Loading Plastic Cards in the Input Tray](#)

[Scanning with Document Capture Pro in Standard View - Windows](#)

[Scanning with Document Capture Pro in Simple View - Windows](#)

[Loading Special Documents](#)

Saving Scanned Documents as a Searchable PDF Using Epson Scan 2

You can scan a document and save the text in a searchable PDF. In a searchable PDF, text is recognized using Optical Character Recognition (OCR) and then embedded in the scanned original.

Note: The required Epson Scan 2 OCR Component is installed automatically when you install your product software as instructed on the *Start Here* sheet. If you install your scanner software programs individually, be sure to also install this component if you want to perform OCR.

1. Load your original in the product for scanning.
2. Start Epson Scan 2.
3. Select your scan settings.
4. Click **Preview** and adjust the area you want to scan, if necessary.
5. Select **Searchable PDF** as the Image Format setting.
6. Select **Options** from the Image Format list.

You see this window:

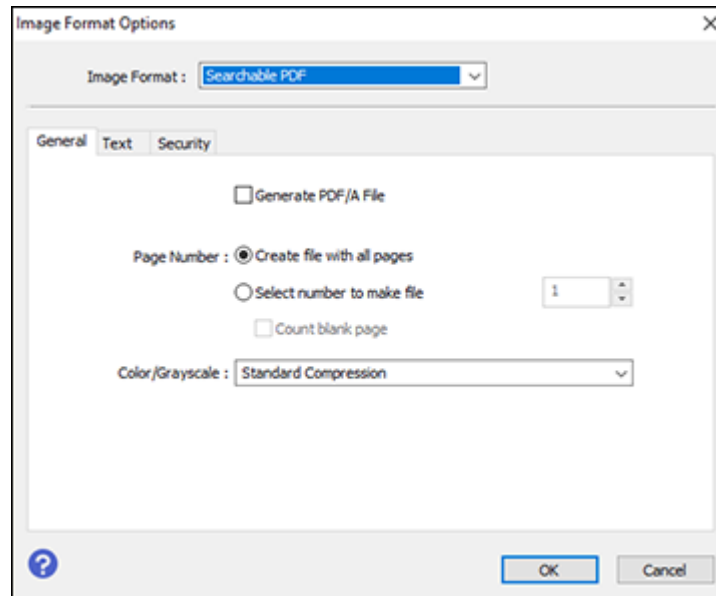

7. Select any of the options on the **General** tab.
8. Select the **Text** tab.
9. Make sure the language used in the document text is selected as the **Text Language** setting.
10. Select the **Security** tab if you want to add a password to the PDF or protect printing or editing properties.
11. Click **OK**.
12. Confirm the **File Name** setting and select a **Folder** setting for your document.
13. Click **Scan**.

The scanned image is saved as a searchable PDF.

Parent topic: [Scanning Special Projects](#)

Saving Scanned Documents as a Searchable PDF with Document Capture - Mac

You can scan a document with Document Capture and save the text in a searchable PDF. In a searchable PDF, text is recognized using Optical Character Recognition (OCR) and then embedded in the scanned original.

Note: The settings may vary, depending on the software version you are using. See the Help information in Document Capture for details.

1. Load your original in the product for scanning.
2. Open the **Applications** folder, open the **Epson Software** folder, and select **Document Capture**.

You see a window like this:

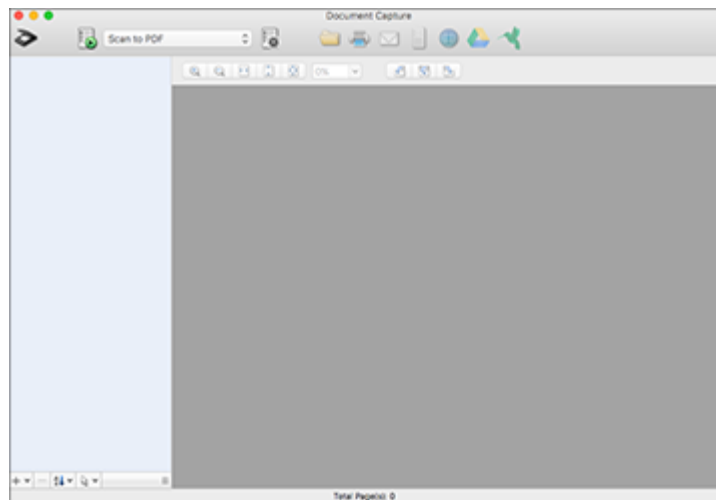

Note: You may need to select your scanner from the scanner list.

3. Click the  **Scan** icon.

You see a window like this:

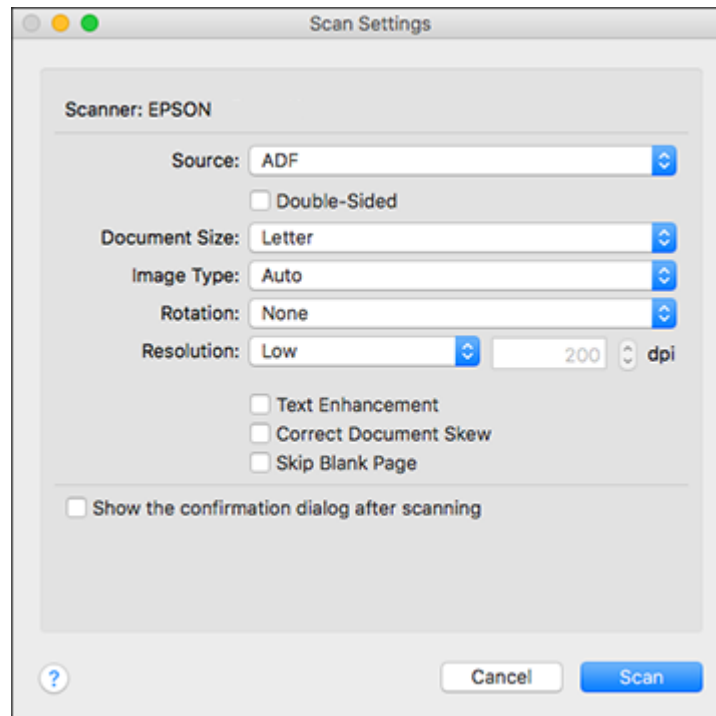

Note: If you want to use a scan job that you created instead, select it from the Job list in the Document Capture window, click the  Start Job button, and skip the rest of these steps.

4. Select any displayed scan settings you want to use.

Note: See the Help information in Document Capture for details.

5. If you want to select detailed scan settings, close the Scan Settings window, open the **Scan** menu at the top of the Mac desktop, and select **Displays the EPSON Scan Setup Screen**.
6. Click the  Scan icon and select any detailed scan settings you want to use from the Epson Scan 2 window.
7. Click **Scan**.

You see a preview of your scan in the Document Capture window.

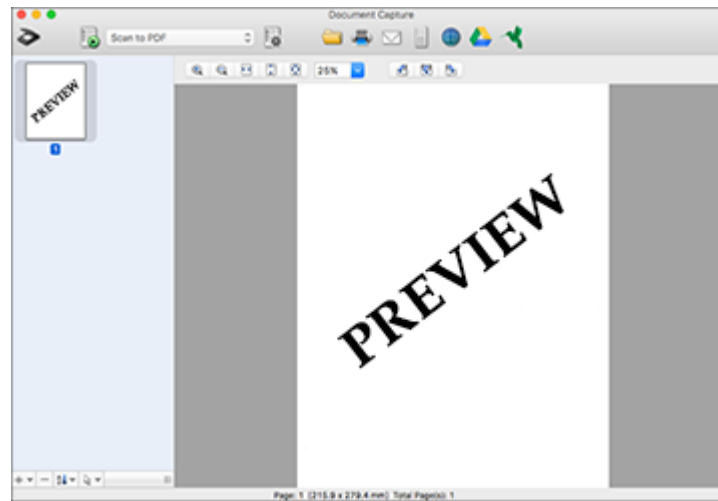

Note: You may have to close the Epson Scan 2 window to view your scan in the Document Capture window.

8. If you would like to scan additional originals and add them to the current captured images, click the + icon, select **Acquire from Scanner**, and repeat the previous steps.
9. Check the scanned images and edit them as necessary.
10. Open the **File** menu at the top of the Mac desktop and select **Save As**.
11. Select **PDF** as the **File Type** setting and click the **Options** button.
12. Select the **Create Searchable PDF** checkbox and click **OK**.
13. Click one of the Destination icons to choose where to send your scanned file. (If you cannot see all of the icons below, click the arrow next to the icons.)





14. Depending on the destination you chose, click **OK** or **Send** to complete the operation.

Parent topic: [Scanning Special Projects](#)

Saving a Scan as an Office Format File - Windows

You can use Document Capture Pro (Windows) to save your scans in one of the following Microsoft Office file formats: Microsoft Word (.docx), Microsoft Excel (.xlsx), or Microsoft PowerPoint (.pptx).

Note: The settings may vary, depending on the software version you are using. See the help information in Document Capture Pro for details.

1. Load your original in the product.
2. Do one of the following to start Document Capture Pro:
 - **Windows 10:** Click  and select **Epson Software > Document Capture Pro**.
 - **Windows 8.x:** Navigate to the **Apps** screen and select **Document Capture Pro**.
 - **Windows (other versions):** Click  or **Start**, and select **All Programs** or **Programs**. Select **Epson Software > Document Capture Pro**.
3. If you see a **Switch to Simple View** button in the upper right corner of the window, click it.

You see a window like this:

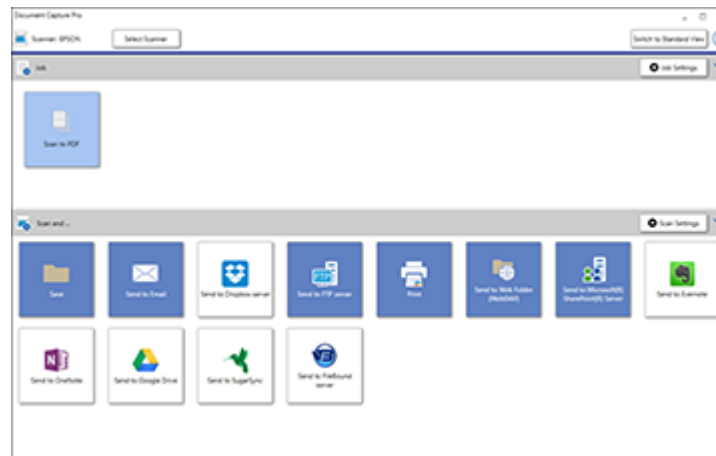

4. Click the **Scan Settings** button.

You see a window like this:

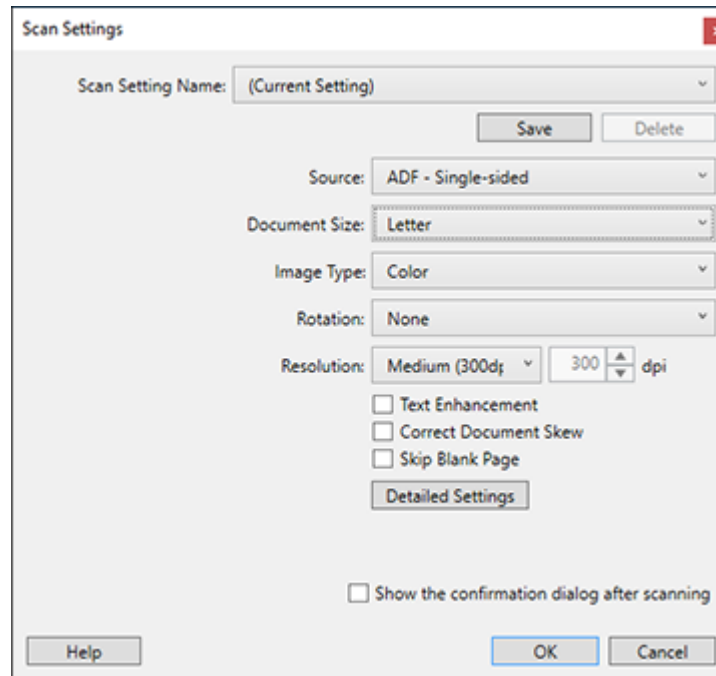

5. Select any displayed settings you want to use and click **OK**.

Note: See the help information in Document Capture Pro for details.

6. Click one of the destination icons (except **Print**) to choose where to send your scanned files. Your product starts scanning and you see the settings window.
7. Select the Office format file you want to use from the **File Type** drop-down list.
8. Click **Option** to display additional settings.
9. Select any additional settings as necessary and click **OK**.

Note: See the help information in Document Capture Pro for details.

10. Confirm your settings and click **OK**.

Your originals are saved in the Office file format you selected.

Parent topic: [Scanning Special Projects](#)

Saving a Scan as an Office Format File - Mac

You can use Document Capture (Mac) to save your scans in one of these Microsoft Office file formats: Microsoft Word (.docx) and Microsoft Excel (.xlsx).

Note: The settings may vary, depending on the software version you are using. See the Help information in Document Capture for details.

1. Load your original in the product for scanning.
2. Open the **Applications** folder, open the **Epson Software** folder, and select **Document Capture**.

You see a window like this:

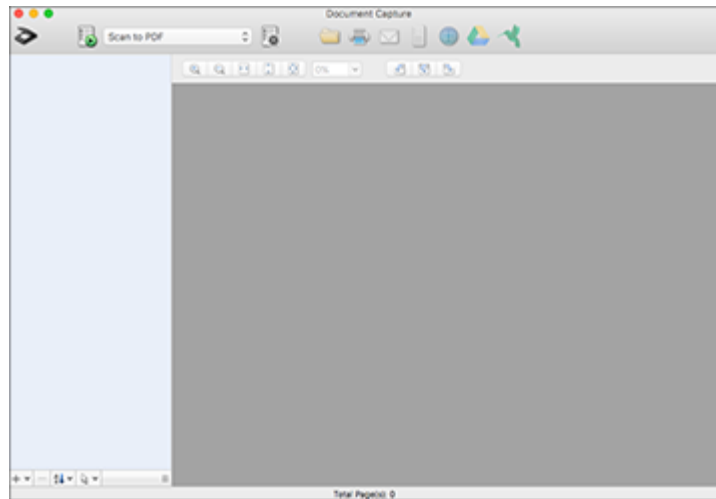

Note: You may need to select your scanner from the scanner list.

3. Click the  **Scan** icon.

You see a window like this:

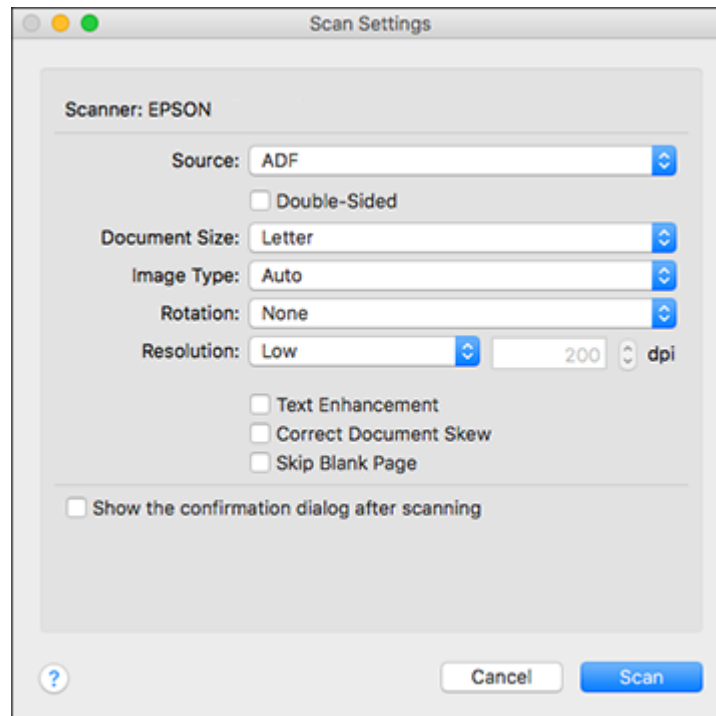

Note: If you want to use a scan job that you created instead, select it from the Job list in the Document Capture window, click the  Start Job button, and skip the rest of these steps.

4. Select any displayed scan settings you want to use.

Note: See the Help information in Document Capture for details.

5. If you want to select detailed scan settings, close the Scan Settings window, open the **Scan** menu at the top of the Mac desktop, and select **Displays the EPSON Scan Setup Screen**.
6. Click the  Scan icon and select any detailed scan settings you want to use from the Epson Scan 2 window.
7. Click **Scan**.

You see a preview of your scan in the Document Capture window.

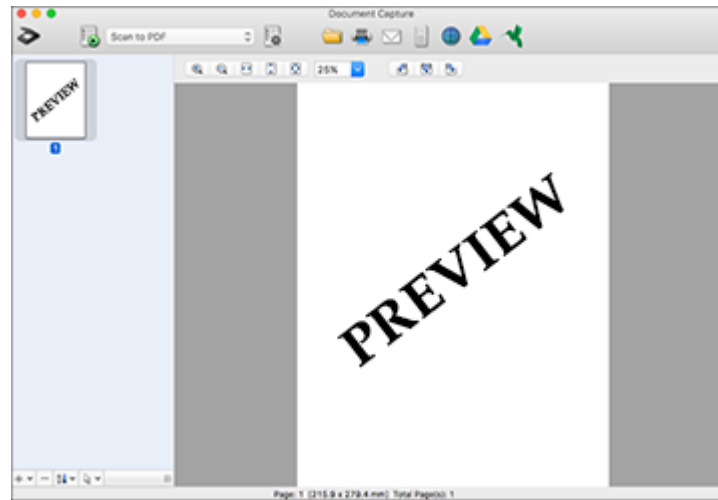

Note: You may have to close the Epson Scan 2 window to view your scan in the Document Capture window.

8. If you would like to scan additional originals and add them to the current captured images, click the + icon, select **Acquire from Scanner**, and repeat the previous steps.
9. Check the scanned images and edit them as necessary.
10. Open the **File** menu at the top of the Mac desktop and select **Save As**.
11. Select **DOCX** (Word) or **XLSX** (Excel) as the **File Type** setting.

Note: The first time you select an Office file type setting in Document Capture, you see a prompt to download a necessary plug-in for Microsoft Office files. Select **Yes** and follow the on-screen instructions to download and install the plug-in to continue.

12. Click the **Options** button, select any necessary Office file type options, and click **OK**.

13. Click one of the Destination icons to choose where to send your scanned file. (If you cannot see all of the icons below, click the arrow next to the icons.)



14. Depending on the destination you chose, click **OK** or **Send** to complete the operation.

Parent topic: [Scanning Special Projects](#)

Convert Scanned Documents to Editable Text (OCR)

You can scan a document and convert the text into data that you can edit with a word processing, spreadsheet, or HTML-editing program. This process is called OCR (Optical Character Recognition).

To scan and use OCR, you need to install an OCR program, such as ABBYY FineReader.



[Scanning Using OCR - Windows](#)

[Scanning Using OCR - Mac](#)

Parent topic: [Scanning Special Projects](#)

Scanning Using OCR - Windows

You can use the ABBYY FineReader OCR program to convert scanned documents to editable text.

1. Load your original in the scanner.
2. Do one of the following to open ABBYY FineReader:
 - **Windows 10:** Click  and select **ABBYY FineReader 12 Sprint > ABBYY FineReader 12 Sprint**.
 - **Windows 8.x:** Navigate to the **Apps** screen and select **ABBYY FineReader 12 Sprint**.
 - **Windows (other versions):** Click  or **Start**, and select **All Programs** or **Programs**. Select **ABBYY FineReader 12 Sprint > ABBYY FineReader 12 Sprint**.

You see a window like this:

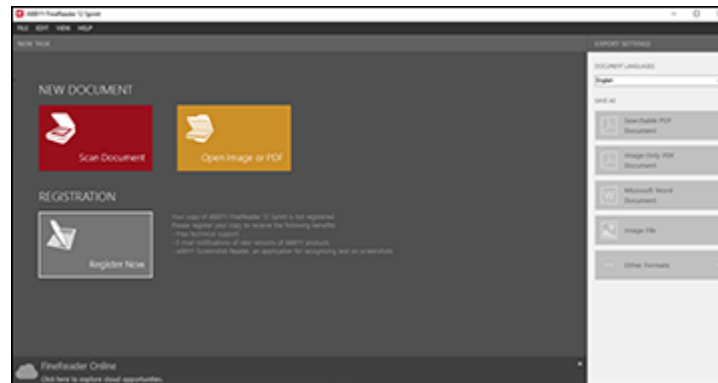

3. Select the language used in the document you are going to scan as the **Document Languages** setting.
4. Click **Scan Document**.
5. If you see the Select Scanner window, select your product and click **OK**.

Note: Do not select a **WIA** option for your product; it will not work correctly.

You see a window like this:

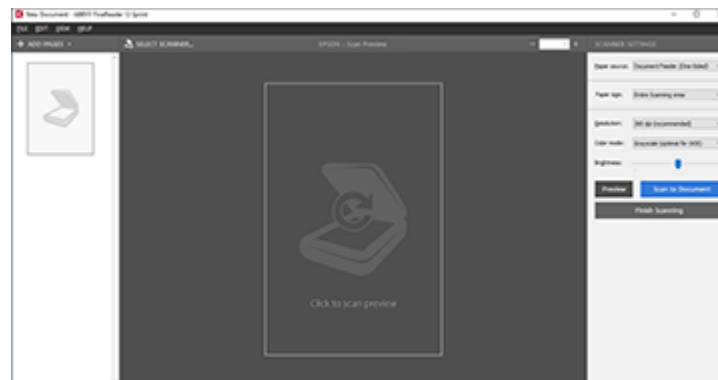

6. Select your scanner settings.

7. Click **Preview** and adjust the area you want to scan, if necessary.
8. Reload the ejected original in the scanner.
9. Click **Scan to Document**.
10. Click **Finish Scanning** and select the program or format you want to scan to.

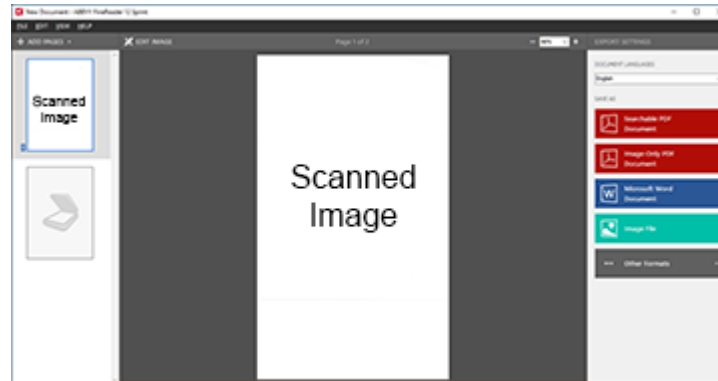

You see the Save As window.

11. Type a name and select a file format for your document.
12. Click **Save**.

Your document is scanned and processed into editable text. The file is then saved and opened in an application associated with the file type you selected, if available on your system.

13. When you are finished scanning, close the ABBYY FineReader window.

Parent topic: [Convert Scanned Documents to Editable Text \(OCR\)](#)

Related tasks

[Loading Documents in the Input Tray](#)

[Loading Plastic Cards in the Input Tray](#)

[Loading Special Documents](#)

Scanning Using OCR - Mac

You can use the ABBYY FineReader OCR program to convert scanned documents to editable text.

1. Load your original in the scanner.
2. Open the **Applications** folder and double-click the **ABBYY FineReader Sprint** icon.

You see a window like this:

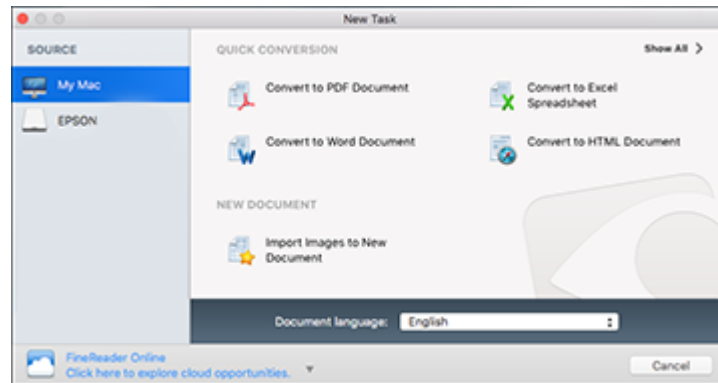

3. Select your product from the **Source** list.
4. Select the language used in the document you are going to scan as the **Document language** setting.
5. Click on **Scan Images to New Document**.

You see a window like this:

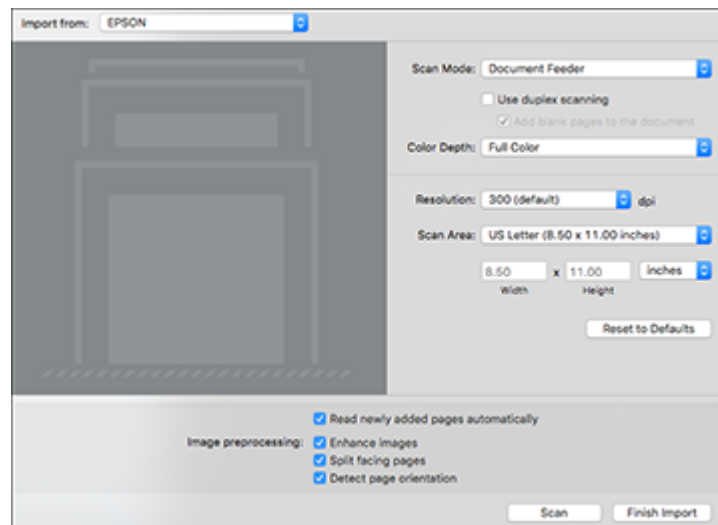

6. Select your scan settings and click **Scan**.

Note: For best results, select **Grayscale** as the **Color Depth** setting.

7. Click **Finish Import**.

You see your scanned image.

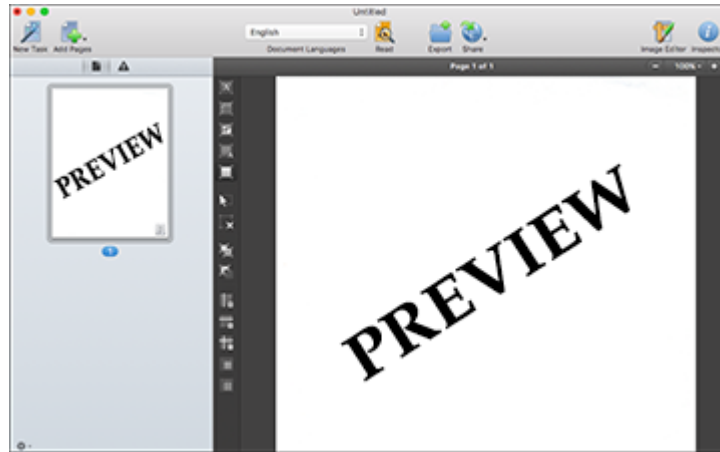

8. Click on the **Export** icon.

9. Select the program or format you want to scan to and click **Next**.

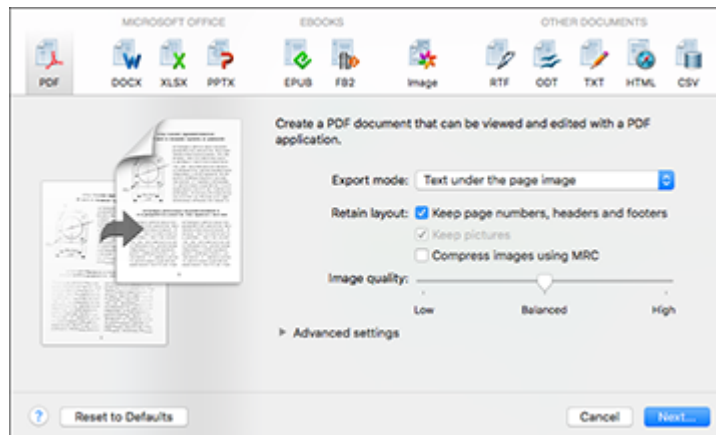

You see the Save Converted File As window:

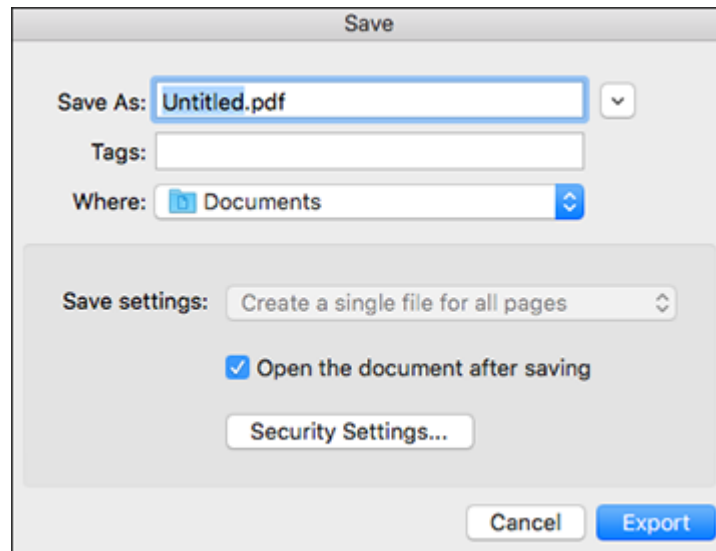

10. Click the **Export** button.

The file is saved and then opened in an application associated with the file type you selected, if available on your system.

Parent topic: [Convert Scanned Documents to Editable Text \(OCR\)](#)

Related tasks

[Loading Documents in the Input Tray](#)



[Loading Plastic Cards in the Input Tray](#)

[Loading Special Documents](#)

Scanning to a SharePoint Server or Cloud Service - Windows

You can use Document Capture Pro (Windows) to upload scanned images to a SharePoint server or a cloud service.

Note: The settings may vary, depending on the software version you are using. See the help information in Document Capture Pro for details.

1. Load your original in the product.
2. Do one of the following to start Document Capture Pro:
 - **Windows 10:** Click  and select **Epson Software > Document Capture Pro**.
 - **Windows 8.x:** Navigate to the **Apps** screen and select **Document Capture Pro**.
 - **Windows (other versions):** Click  or **Start**, and select **All Programs** or **Programs**. Select **Epson Software > Document Capture Pro**.
3. If you see a **Switch to Simple View** button in the upper right corner of the window, click it.
You see a window like this:

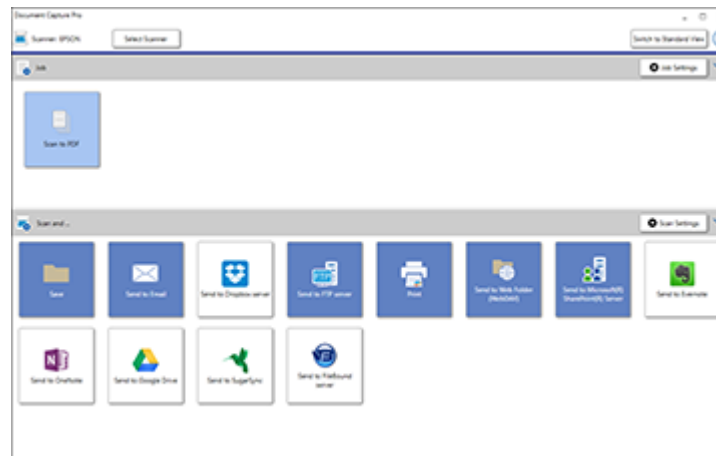

4. Click the **Scan Settings** button.

Note: If you do not see any icons, click the **V** symbol next to the **Job Settings** button.

You see a window like this:

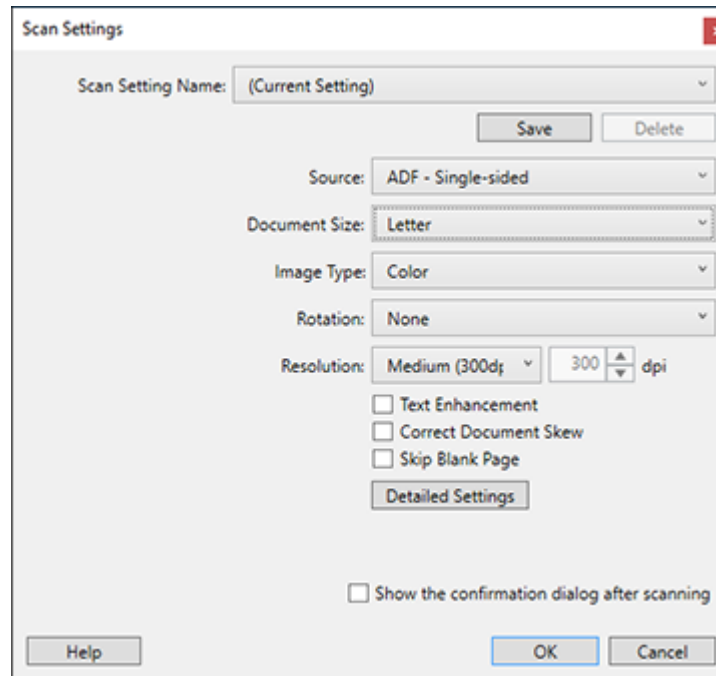

5. Select any displayed settings you want to use and click **OK**.

Note: See the help information in Document Capture Pro for details.

6. Click one of the cloud server or service destination icons in the **Scan and...** section of the window. Your product starts scanning and you see the settings window.

Note: If you cannot see all of the icons, the service software may not be installed or the service may not be available on your platform.

7. Enter any required information to set up the destination. You may need to log in to your cloud service to authenticate the connection and allow Document Capture Pro to access the cloud service. If you have previously created a saved setting for the destination, select it from the drop-down list.

8. Adjust any settings and click **OK**.

Note: See the help information in Document Capture Pro for details.

Your originals are uploaded to the indicated server or cloud service.

Parent topic: [Scanning Special Projects](#)

Related tasks

[Loading Documents in the Input Tray](#)

[Loading Plastic Cards in the Input Tray](#)

[Scanning with Document Capture Pro in Standard View - Windows](#)

[Scanning with Document Capture Pro in Simple View - Windows](#)

[Loading Special Documents](#)

[Scanning with Document Capture - Mac](#)

Cleaning and Transporting Your Scanner

See these sections if you need to clean or transport your scanner.

[Cleaning Your Scanner](#)

[Cleaning Inside Your Scanner](#)

[Checking the Scanner Roller Counter](#)

[Replacing the Scanner Rollers](#)

[Transporting Your Scanner](#)

Cleaning Your Scanner

To keep your product working at its best, you should clean it several times a year.

Caution: Do not use a hard brush, alcohol, or paint thinner to clean the product or you may damage it. Do not use oil or other lubricants inside the product or let water get inside it. Do not open the product's outer case.

1. Turn off the scanner and unplug the AC adapter.
2. Disconnect any connected cables.
3. Clean the outer case with a soft, dry cloth. Do not use liquid or chemical cleansers.

Note: If the outer case still requires additional cleaning, use a slightly damp cloth to wipe the outer case. Then wipe the case with a soft, dry cloth.

Parent topic: [Cleaning and Transporting Your Scanner](#)

Cleaning Inside Your Scanner

Clean inside your scanner regularly to make sure that no dust builds up on the glass scanning surfaces. Dust can cause spots or lines in your scanned images.

Caution: Because of the speed at which photos are scanned, dust particles on your photos can cause white lines to appear in scanned images, and in extreme cases can lightly scratch the protective finish on your photos. For best results, wipe off the front and back of your photos before scanning and use the included microfiber cloth to clean the scanner rollers after every 300 scans, or even before each scanning session.

Caution: Do not use a hard brush, alcohol, or paint thinner to clean the product or you may damage it. Do not use oil or other lubricants inside the product or let water get inside it.

For more information, view this [Epson support video](#).

1. Turn off the scanner and unplug the AC adapter.
2. Disconnect any connected cables.
3. Pull down on the cover open lever and open the scanner cover.

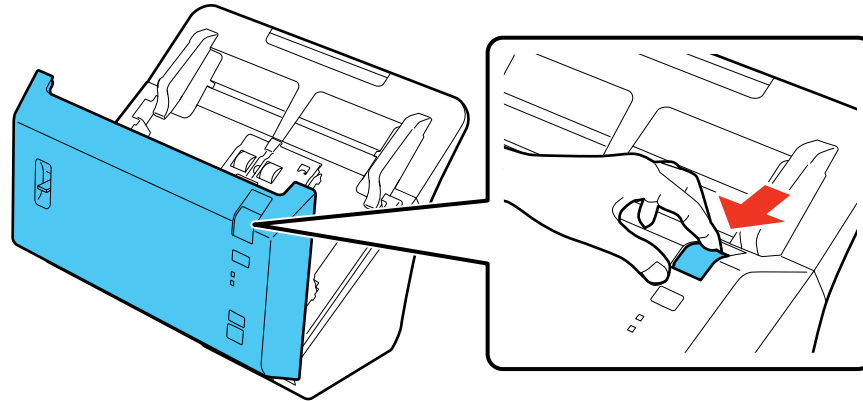

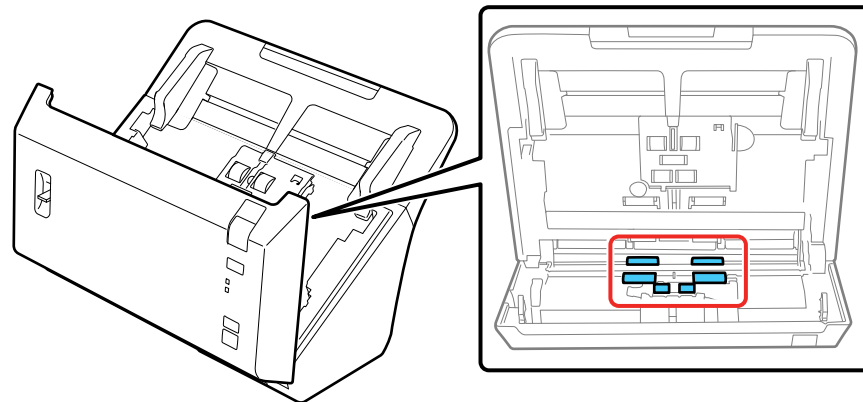

4. Use the included microfiber cloth or a soft, dry cloth to wipe off any dust or dirt on the interior of the scanner.
5. Wipe off any dust or dirt on the rollers inside the scanner cover.

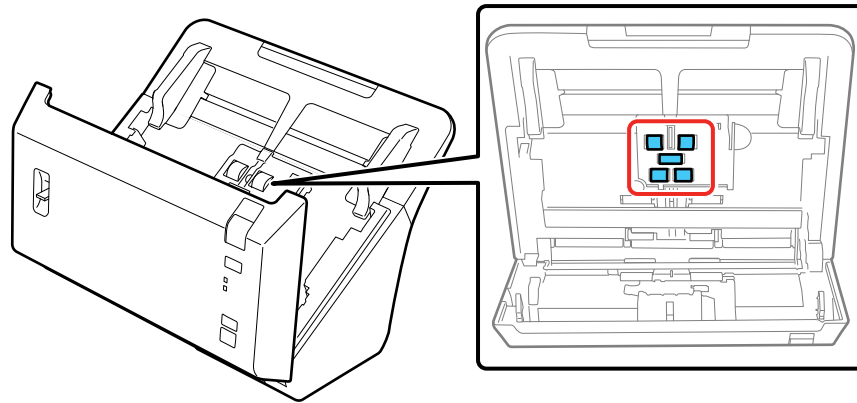

6. Wipe off any dust or dirt on the pickup rollers.



7. Plug in the AC adapter and press the  power button to turn on the scanner.
8. Hold down the  scan button for at least two seconds, and press the  scan button several times to rotate the rollers shown here. Wipe off any dust or dirt on the rollers as they rotate.

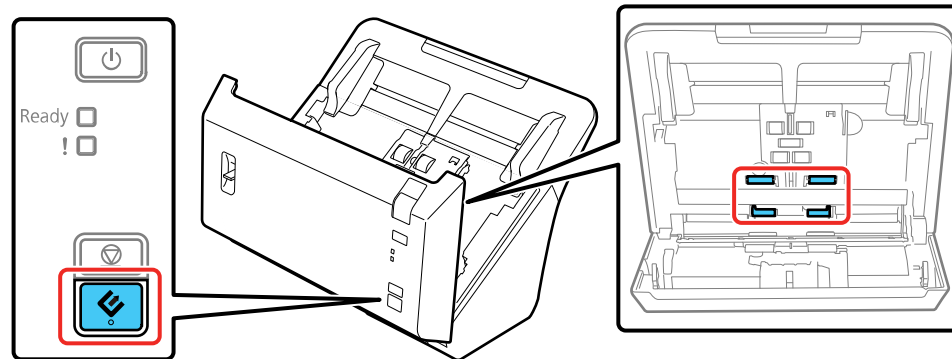

9. Turn off the scanner and unplug the AC adapter.
10. Wipe off any dust or dirt on the glass scanning surfaces using the included microfiber cloth or a soft, dry cloth. Be sure to clean the entire surface of both glass scanning surfaces, including the light gray

portion. If the glass surface is stained with grease or some other hard-to-remove material, use a small amount of glass cleaner on a soft cloth to remove it. Wipe off all remaining liquid.

Caution: Do not spray glass cleaner directly on the scanning surfaces. Do not wipe the scanner rollers with the same microfiber cloth used with glass cleaner. Be careful not to place too much force on the glass.

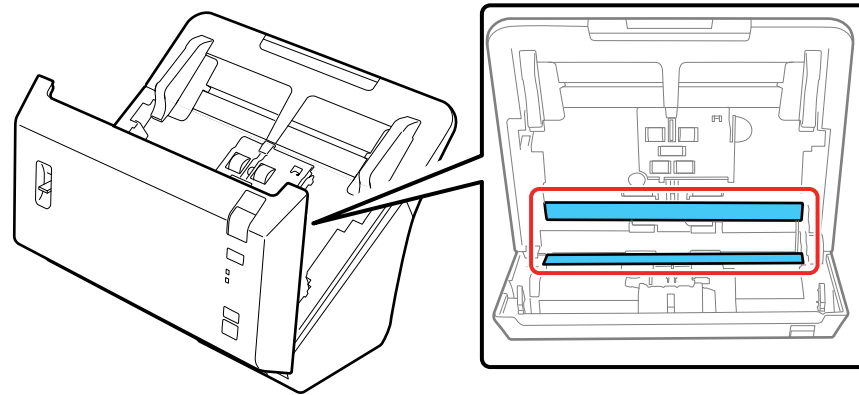



11. Close the scanner cover.
12. Plug in the AC adapter and turn on the scanner.

Parent topic: [Cleaning and Transporting Your Scanner](#)

Checking the Scanner Roller Counter

Check the scanner roller counter to determine when your rollers need to be replaced. When you replace the scanner rollers, reset the scanner roller counter so you know when you may need to replace the rollers again.

1. Make sure the scanner is turned on and connected to your computer.
2. Do one of the following to open the Epson Scan 2 Utility:
 - **Windows 10:** Click  and select **EPSON > Epson Scan 2 Utility**.
 - **Windows 8.x:** Navigate to the **Apps** screen and select **Epson Scan 2 Utility**.
 - **Windows (other versions):** Click  or **Start > All Programs** or **Programs > EPSON > Epson Scan 2 > Epson Scan 2 Utility**.

- **Mac:** Open the **Applications** folder, click **Epson Software**, and click **Epson Scan 2 Utility**.
3. Click the **Counter** tab.
You see a screen like this:

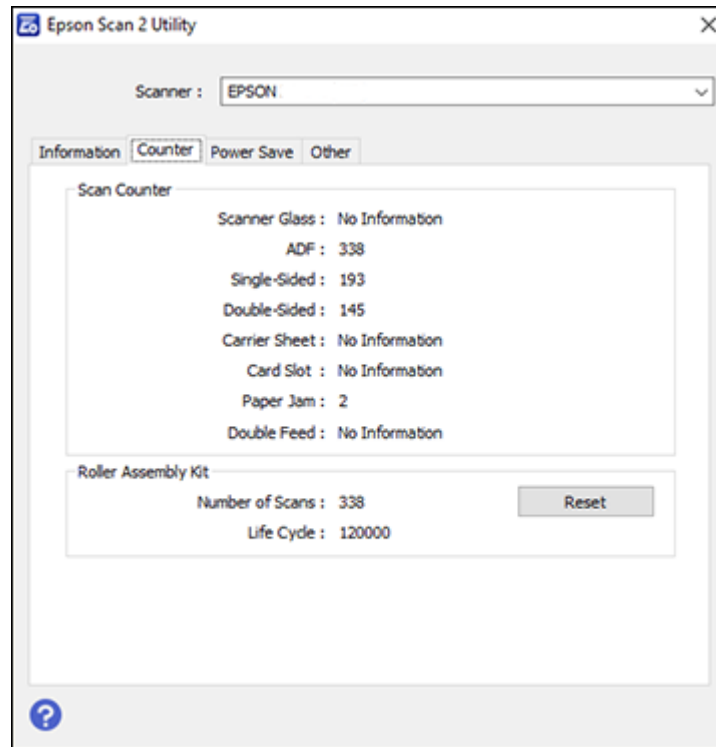

4. If the number in the **Number of Scans** field exceeds the number displayed as the **Life Cycle** of the rollers, it is time to replace the rollers.
5. Close the Epson Scan 2 Utility.

Parent topic: [Cleaning and Transporting Your Scanner](#)

Related topics

[Replacing the Scanner Rollers](#)

Replacing the Scanner Rollers

See these sections if you need to replace the rollers in your scanner.

[Replacing the Pickup Rollers](#)

[Replacing the Separation Rollers](#)

[Resetting the Scanner Roller Counter](#)

Parent topic: [Cleaning and Transporting Your Scanner](#)

Related tasks

[Checking the Scanner Roller Counter](#)

Replacing the Pickup Rollers

Replace the pickup rollers after you have scanned 120,000 times. Check the scanner roller counter to see when you need to replace the rollers.

1. Turn off the scanner and unplug the AC adapter.
2. Disconnect any connected cables.
3. Pull down on the cover open lever and open the scanner cover.

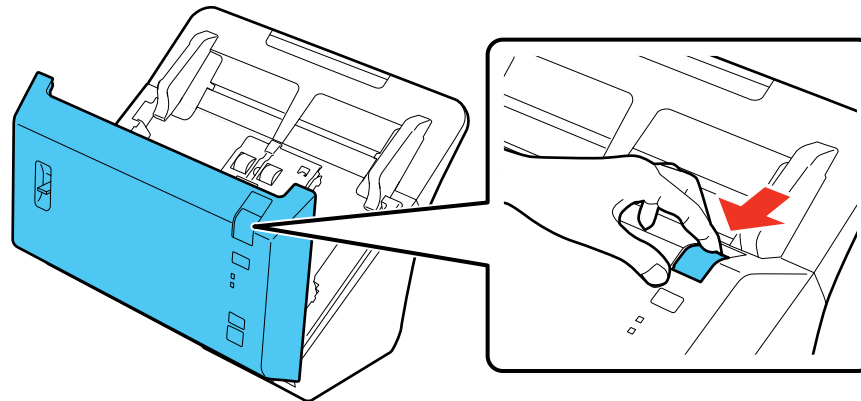

4. Squeeze the tab on the right side of the pickup roller cover and open the cover.

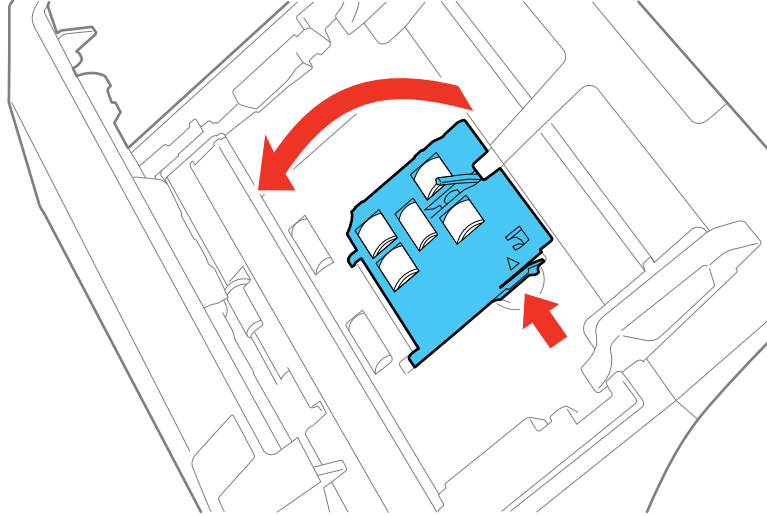

Caution: Do not place too much force on the arm inside the cover when replacing the pickup roller.

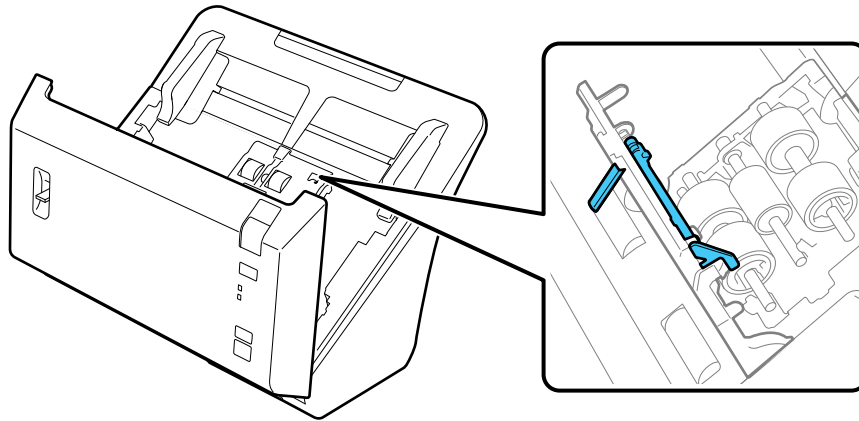

5. Slide the pickup rollers to the right and remove them.



6. Remove the lower pickup roller from the spindle.

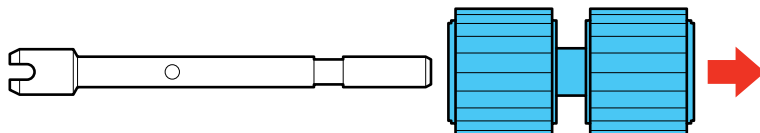

7. Place the new lower pickup roller on the spindle, rotate the roller, and slide it all the way onto the spindle.

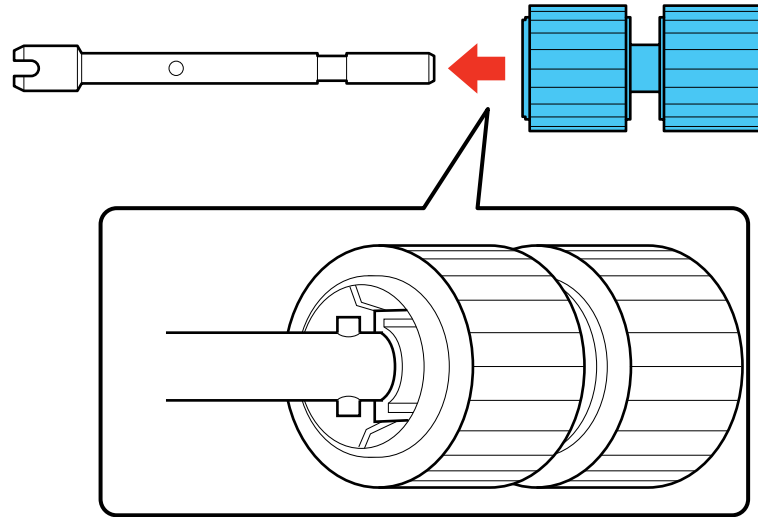

8. Install the lower pickup roller spindle by aligning the notches on the roller and sliding it to the left.

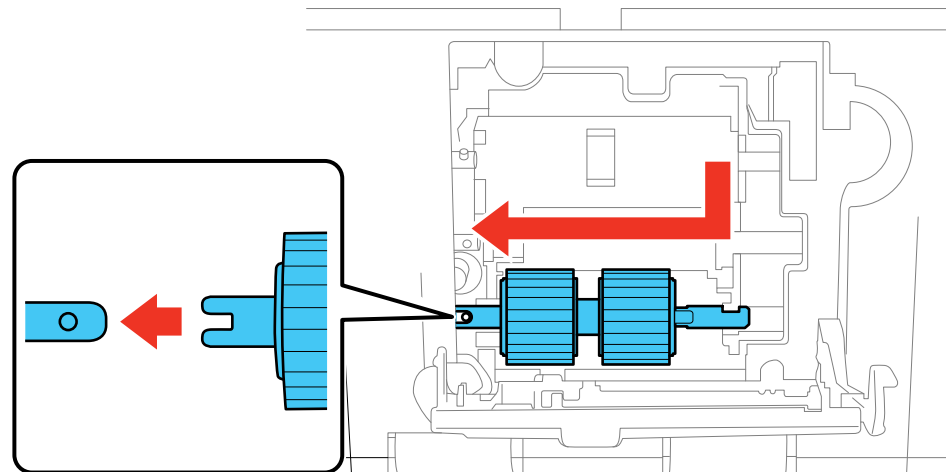

9. Remove the middle pickup roller from the spindle.

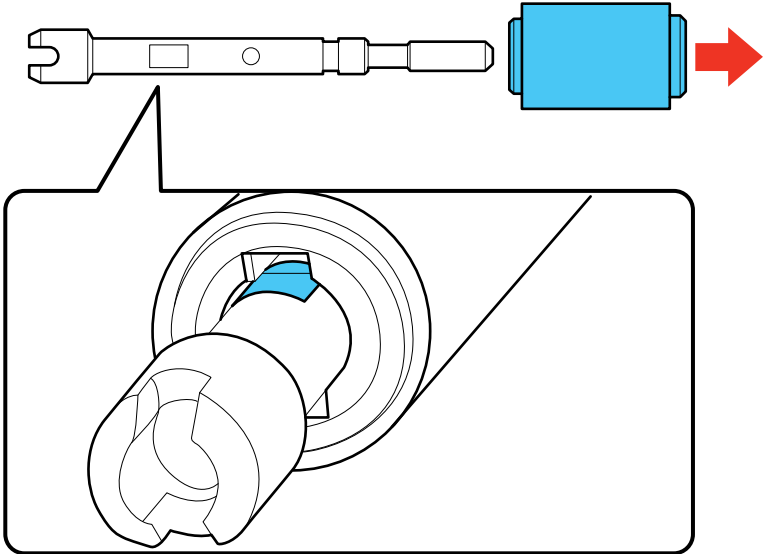

10. Place the new middle pickup roller on the spindle, rotate the roller to line up the notches, and slide it all the way onto the spindle.

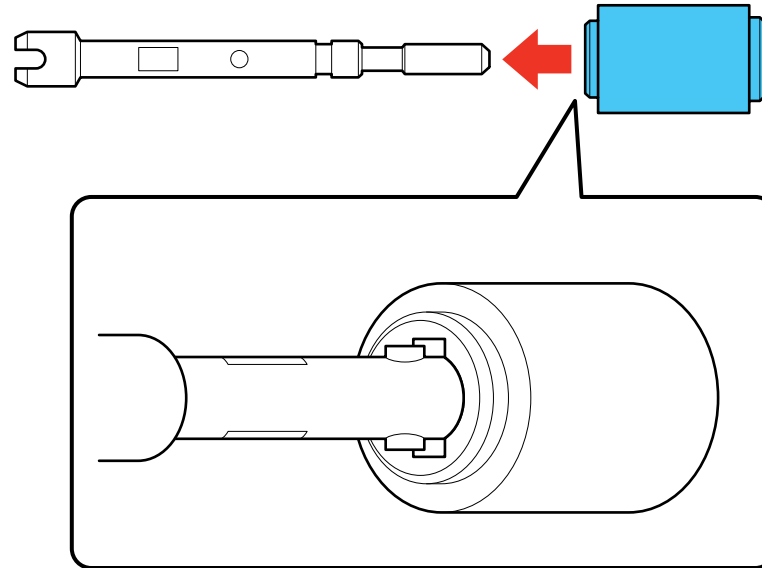

11. Install the middle pickup roller spindle by aligning the notches on the spindle and sliding it to the left.

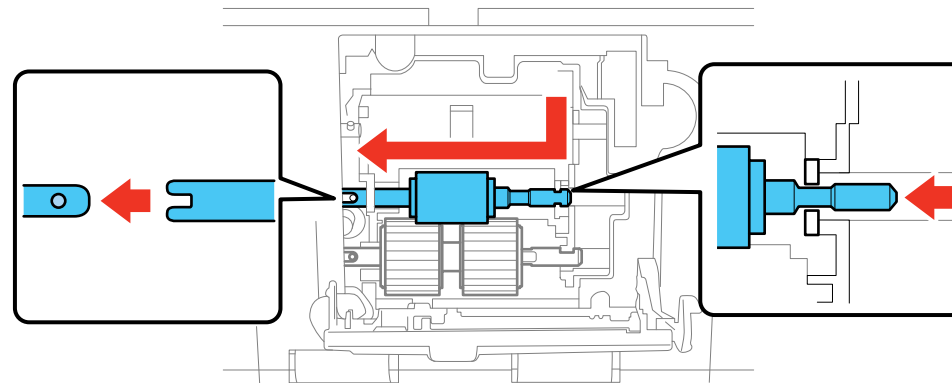

12. Remove the upper pickup roller from the spindle.

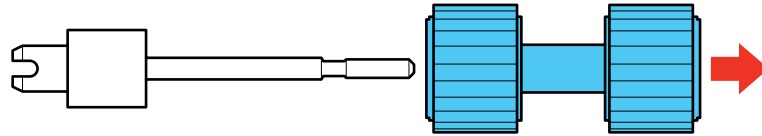

13. Place the new upper pickup roller on the spindle, rotate the roller to line up the notches, and slide it all the way onto the spindle.

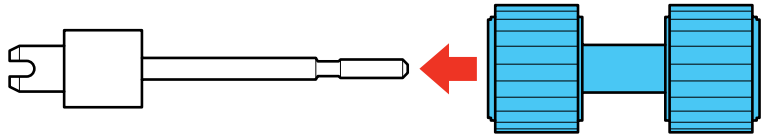

14. Install the upper pickup roller spindle by aligning the notches on the spindle and sliding it to the left.

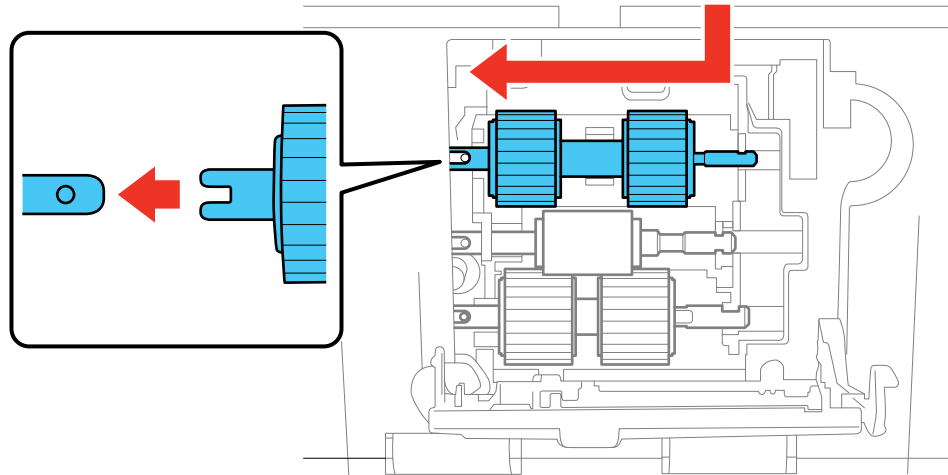

15. Close the pickup roller cover.

Note: If you are not able to close the cover, the pickup rollers are not installed correctly. Make sure the rollers are pushed all the way to the left, then try to close the cover. If you still cannot close the cover, remove the rollers, reinstall them, and try to close the cover again.

16. Replace the separation rollers.

Parent topic: [Replacing the Scanner Rollers](#)

Related tasks

[Checking the Scanner Roller Counter](#)

[Replacing the Separation Rollers](#)

Replacing the Separation Rollers

Replace the separation rollers after you have scanned 120,000 times. Check the scanner roller counter to see when you need to replace the rollers.

1. Turn off the scanner and unplug the AC adapter.
2. Disconnect any connected cables.
3. Pull down on the cover open lever and open the scanner cover.

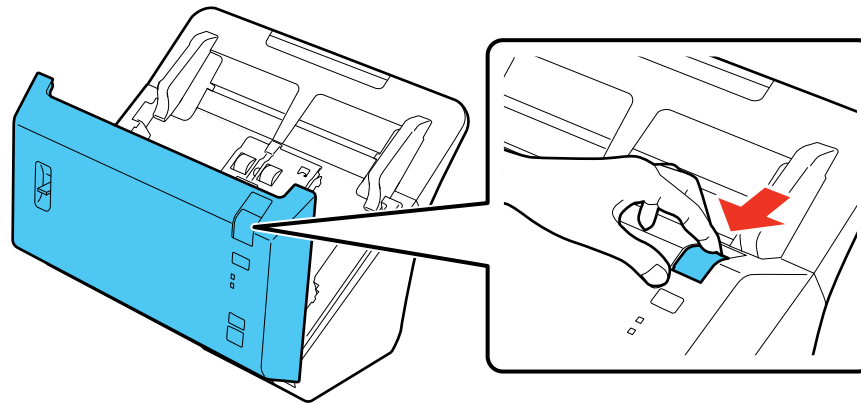

4. Press down on the separation roller cover latch inside the scanner cover and pull down the cover to open it.

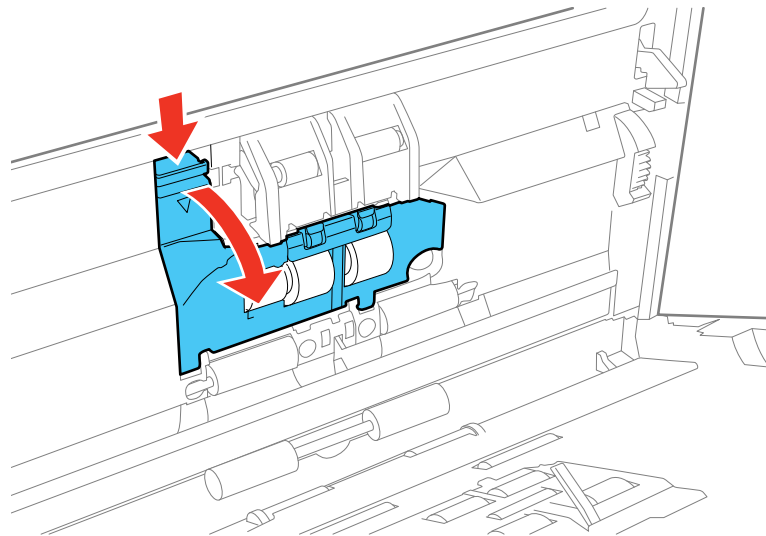

Caution: Be careful not to apply too much force when opening the cover.

5. Press in on the separation roller to release it, then slide the roller to the side and remove it.

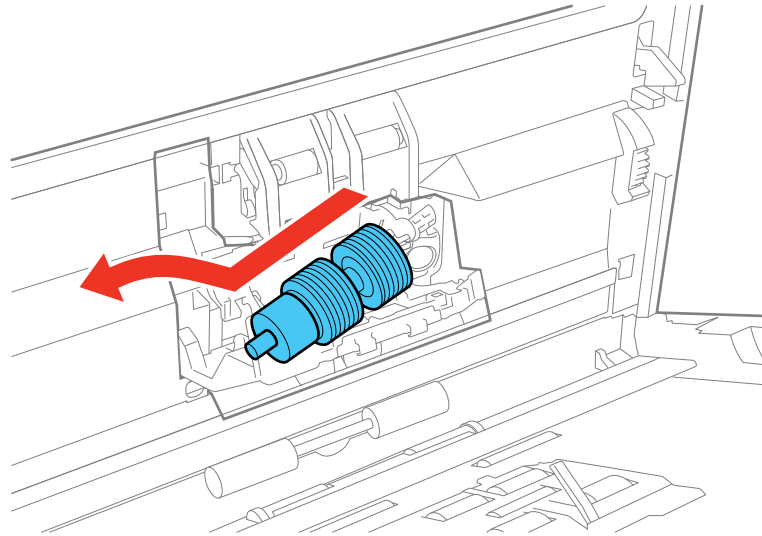

6. Remove the separation roller from the spindle.

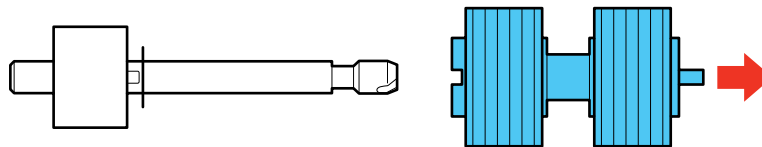

7. Slide the new separation roller onto the spindle as shown. Make sure that the notches on the roller and spindle align properly. You hear a click when the roller is firmly locked into place.

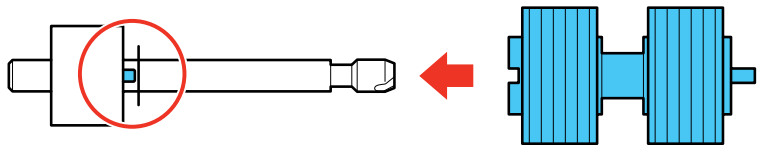

Note: Check that there are no gaps between the roller and spindle.

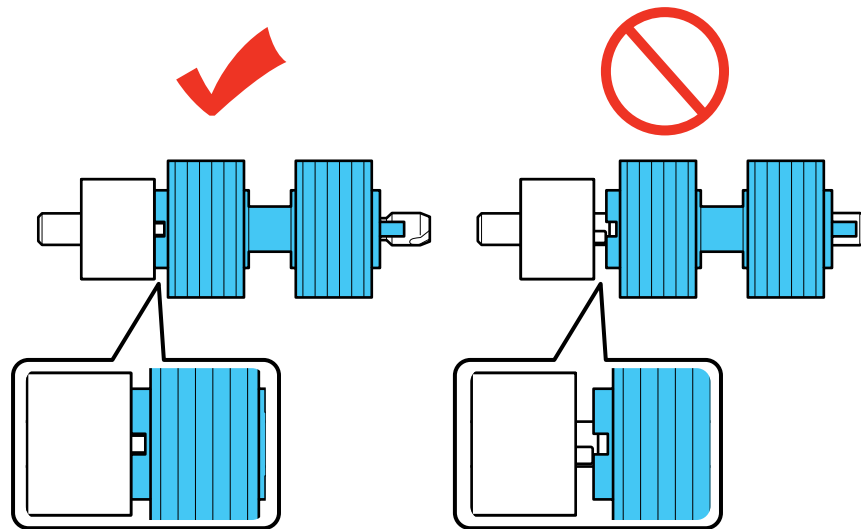

8. Align the notches on the spindle and the scanner, then slide the separation roller into the scanner and gently push it until it clicks into place.

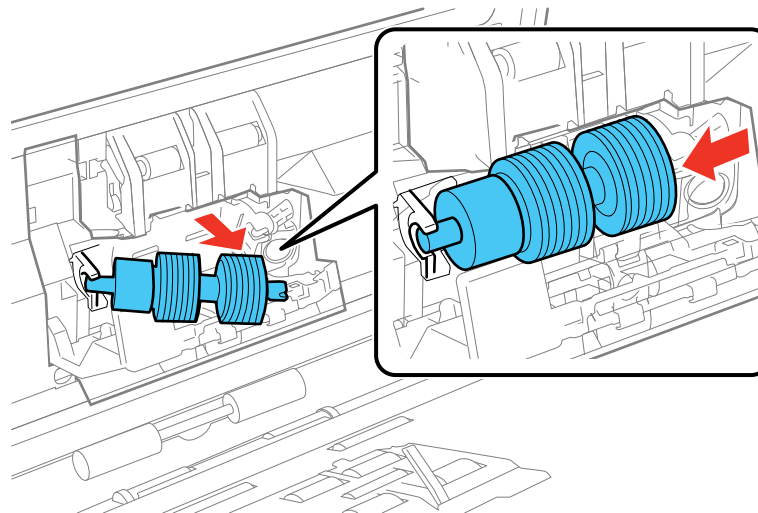

9. While applying gentle pressure on the separation roller, close the separation roller cover.

Note: If you are not able to close the cover, the roller is not installed correctly. Make sure the roller is pushed all the way to the right, then try to close the cover. If you still cannot close the cover, remove the roller, reinstall it, and try to close the cover again.

10. Close the scanner cover.
11. Plug in the AC adapter and turn on the scanner.
12. Reset the roller counter.



Parent topic: [Replacing the Scanner Rollers](#)

Related tasks

[Resetting the Scanner Roller Counter](#)

Resetting the Scanner Roller Counter

When you replace the scanner rollers, reset the scanner roller counter so you know when you may need to replace the rollers again.

1. Make sure the scanner is turned on and connected to your computer.
2. Do one of the following to open the Epson Scan 2 Utility:
 - **Windows 10:** Click  and select **EPSON > Epson Scan 2 Utility**.
 - **Windows 8.x:** Navigate to the **Apps** screen and select **Epson Scan 2 Utility**.
 - **Windows (other versions):** Click  or **Start > All Programs** or **Programs > EPSON > Epson Scan 2 > Epson Scan 2 Utility**.
 - **Mac:** Open the **Applications** folder, click **Epson Software**, and click **Epson Scan 2 Utility**.
3. Click the **Counter** tab.

You see a screen like this:

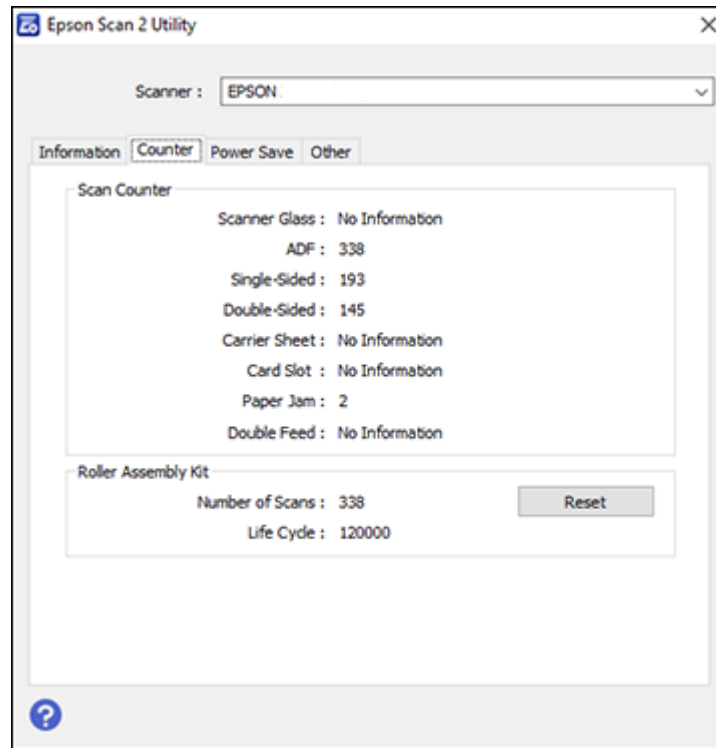

4. Click **Reset**.
The Number of Scans field changes to 0 (zero).
5. Close the Epson Scan 2 Utility.

Parent topic: [Replacing the Scanner Rollers](#)

Related tasks

[Checking the Scanner Roller Counter](#)

Transporting Your Scanner

If you need to ship your product, transport it a long distance, or store it for an extended period, prepare it for transportation as described here.

1. Turn off the scanner and unplug the AC adapter.
2. Disconnect any connected cables.
3. Close the input tray extension and the output tray.
4. Remove the input tray by pulling it towards the scanner cover and then pulling it off the scanner.

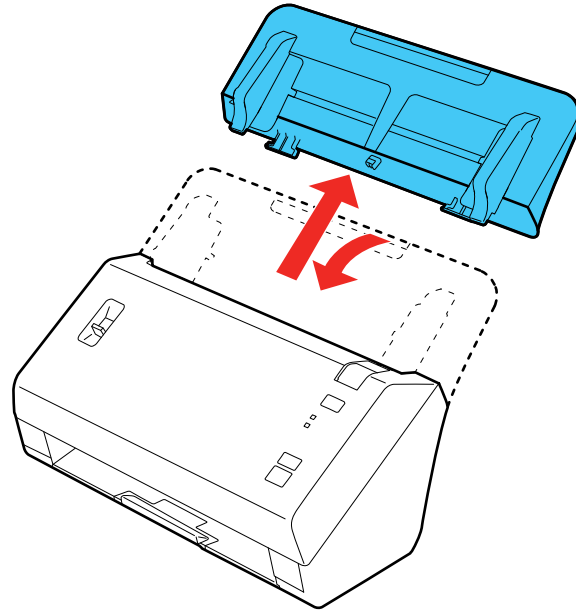

5. Place the scanner in its original packing materials, if possible, or use equivalent materials with cushioning around the product.

Parent topic: [Cleaning and Transporting Your Scanner](#)

Solving Problems

Check these sections for solutions to problems you may have using your product.

[Scanner Light Status](#)

[Solving Scanning Problems](#)

[Solving Scanned Image Quality Problems](#)

[Uninstall Your Scanner Software](#)

[Where to Get Help](#)

Scanner Light Status

You can often diagnose problems with your scanner by checking its lights.

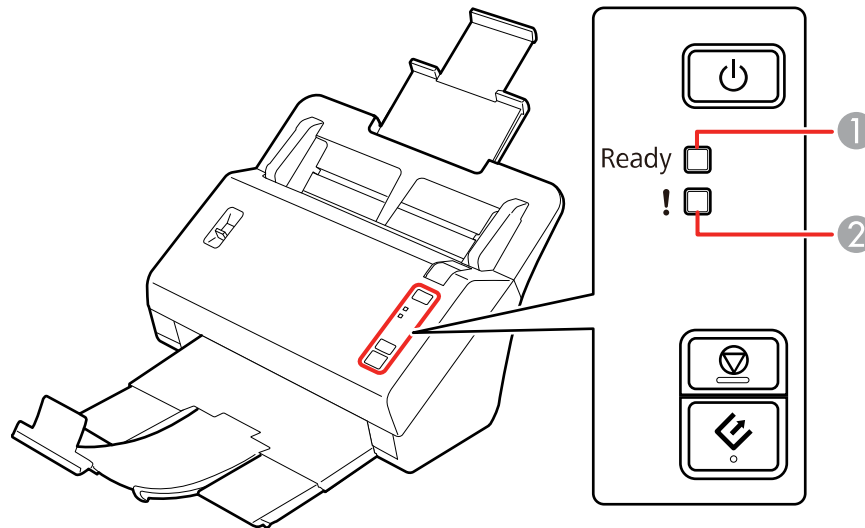

1 **Ready** light

2 **! error** light

Light status	Condition/solution
Ready light is on	The scanner is turned on and ready to scan.
Ready light is flashing	The scanner is scanning or initializing. Wait for the Ready light to stop flashing before turning off the scanner.
! error light is on	An error has occurred. Try the following: <ul style="list-style-type: none"> • Check the scanner connection to your computer to make sure it is secure. • Make sure the scanner cover is closed and there is no paper jammed inside. • If the ! error light is still on, turn off the scanner and turn it on again. If the error continues, the scanner may be malfunctioning. Contact Epson for support.
! error light and Ready light are flashing alternately	The scanner firmware is updating. Do not turn off the scanner or disconnect any cables until the lights have stopped flashing.
! error light and Ready light are flashing at the same time	A scanner error has occurred. Turn the scanner off and then back on again. If the error continues, contact Epson for support.

Parent topic: [Solving Problems](#)

Related references

[Scanner Buttons and Lights](#)

Solving Scanning Problems

Check these solutions if you have problems scanning with your product.

[Scanner Does Not Turn On or Turns Off Unexpectedly](#)

[Scanner Button Does Not Work as Expected](#)

[Scanning Software Does Not Operate Correctly](#)

[Cannot Share or Upload Photos Using FastFoto](#)

[Cannot Start Epson Scan 2](#)

[Original Feeds Incorrectly in Scanner](#)

[Original Jams in Scanner](#)

[Scanning is Slow](#)

Parent topic: [Solving Problems](#)

Scanner Does Not Turn On or Turns Off Unexpectedly

If the scanner does not turn on or if it turns off unexpectedly, try these solutions:

- Make sure the AC adapter is securely connected to the scanner and to a working electrical outlet.
- If the scanner turns off unexpectedly, you may need to adjust the **AC power or AC adapter** setting in the Epson Scan 2 Utility.

Parent topic: [Solving Scanning Problems](#)

Related tasks

[Changing the Power Off Setting](#)

Scanner Button Does Not Work as Expected

If the scanner button does not start the correct program or perform the correct action, try these solutions:

- Make sure the Epson FastFoto software is installed correctly. If necessary, uninstall and reinstall it.
- Make sure the FastFoto software selector on the Windows status bar or Mac menu bar has the correct software selected.
- Check the USB cable connection between the computer and scanner.
- Check that the correct scanner is selected using the Epson Scan 2 Utility. Make sure your scanner supports Epson Scan 2.
- In Windows, be sure that the scanner is listed under **Imaging Devices** in the Device Manager.
- Make sure Document Capture Pro (Windows) or Document Capture (Mac) is installed correctly. If necessary, uninstall and reinstall it.
- Make sure you have assigned the correct job to the scanner button and change it, if necessary.
- If you selected **Keep Blocking** in a Windows Security Alert window during or after installation of Document Capture Pro, unblock the EEventManager Application program in the Windows security settings; see Windows help for details.
- Check the status of the lights and make sure the scanner is ready to scan.
- Make sure Epson Scan 2 and other applications are installed correctly. If necessary, uninstall and reinstall it.

Parent topic: [Solving Scanning Problems](#)

Related concepts

[Uninstall Your Scanner Software](#)

Related tasks

[Starting a Scan from a Scanner Button](#)

Scanning Software Does Not Operate Correctly

If your scanning software does not operate correctly, try these solutions:

- Make sure your computer has adequate memory and meets the system requirements for your operating system.
- Make sure your computer is not running in a power-saving mode, such as sleep or standby. If so, wake your system and restart your scanning software.
- Make sure the scanner is turned on.
- Make sure the connection between the scanner and your computer is secure.
- If you upgraded your operating system but did not reinstall your scanning software, try reinstalling it.
- In Windows, be sure that the scanner is listed under **Imaging Devices** in the Device Manager.
- Check that the correct scanner is selected using the Epson Scan 2 Utility. Make sure your scanner supports Epson Scan 2.
- Connect the scanner directly to the computer. The scanner may not work properly when connected through a USB hub.
- If you are scanning on a Mac, and you have scanner software from other products installed, uninstall the scanner software for all your products. Then reinstall the scanner software for this product and test it to make sure it works. If it does, reinstall the scanner software for your other products and make sure they all work. If not, contact Epson for support.
- If you are using a TWAIN-compliant program, make sure that the correct product is selected as the **Scanner** or **Source** setting.

Parent topic: [Solving Scanning Problems](#)

Related concepts

[Uninstall Your Scanner Software](#)

Cannot Share or Upload Photos Using FastFoto

If you cannot share or upload photos to a web service using the FastFoto software, try these solutions:

- Make sure the web service is running.
- Make sure your computer has an active Internet connection.
- Confirm that you entered the correct login information for the web service.

- If uploading to Dropbox, make sure the Dropbox application is installed on your computer.

Parent topic: [Solving Scanning Problems](#)

Cannot Start Epson Scan 2

If you cannot start Epson Scan 2, try these solutions:

- Restart your computer.
- Make sure your scanner is turned on and any interface cables are securely connected at both ends.
- Make sure your computer is not running in a power-saving mode, such as sleep or standby. If so, wake your system and restart Epson Scan 2.
- Connect the scanner directly to the computer. The scanner may not work properly when connected through a USB hub.
- If you connected the scanner using a USB cable, make sure it is connected directly to your computer or through only one USB hub.
- Make sure you do not have multiple versions of Epson Scan 2 installed. If you do, uninstall all versions and install one version.
- If you upgraded your operating system but did not reinstall Epson Scan 2, try reinstalling it.
- If you are using a TWAIN-compliant program, make sure that the correct product is selected as the **Scanner** or **Source** setting.

Parent topic: [Solving Scanning Problems](#)

Original Feeds Incorrectly in Scanner

If you have problems feeding originals in your scanner, try these solutions:

Note: Do not repeatedly scan the same photo. Scanning photos multiple times can cause the photos to stick together due to a buildup of static electricity and could potentially damage the photos.

- If multiple photos feed at once, try the following:
 - Make sure the paper separation lever is in the lower position.
 - Load only photos that meet the specifications for your scanner.
 - Wipe the back and front of the photos with a soft, dry, lint-free cloth.
 - Make sure the photos do not have a sticky residue on them.
 - Separate the photos to make sure they are not stuck together.

- If you see a double feed error in the Epson Scan 2 window or the Document Capture Pro window, start Epson Scan 2, select the **Main Settings** tab, select the **Detect Double Feed** setting, and select **Off**.

Note: On a Mac, only Epson Scan 2 displays double feed errors. Document Capture for Mac does not include this setting.

Parent topic: [Solving Scanning Problems](#)

Related references

[Page Separation Lever](#)

Related tasks

[Loading Photos in the Input Tray](#)

[Loading Documents in the Input Tray](#)

[Loading Plastic Cards in the Input Tray](#)

[Loading Special Documents](#)

[Cleaning Inside Your Scanner](#)

[Loading a Photo with a Carrier Sheet](#)

Related topics

[Replacing the Scanner Rollers](#)

Original Jams in Scanner

If an original has jammed inside the scanner, follow these steps:

1. Turn off your scanner.
2. Remove all originals from the input tray.

3. Pull down the cover open lever and open the scanner cover.

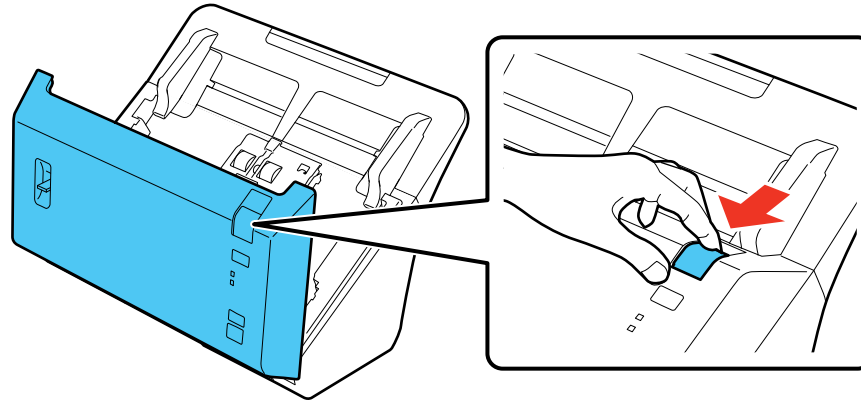

4. Gently pull out any jammed originals from inside the scanner.

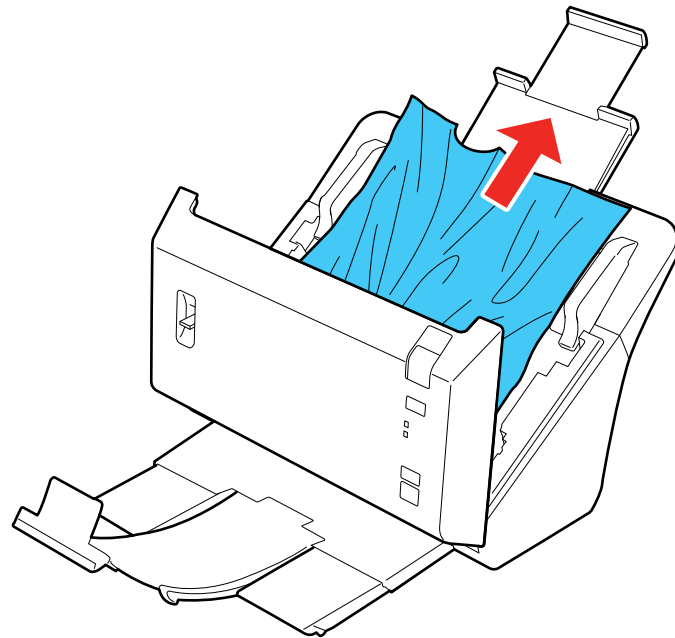

5. Gently pull out any jammed originals from the output tray.

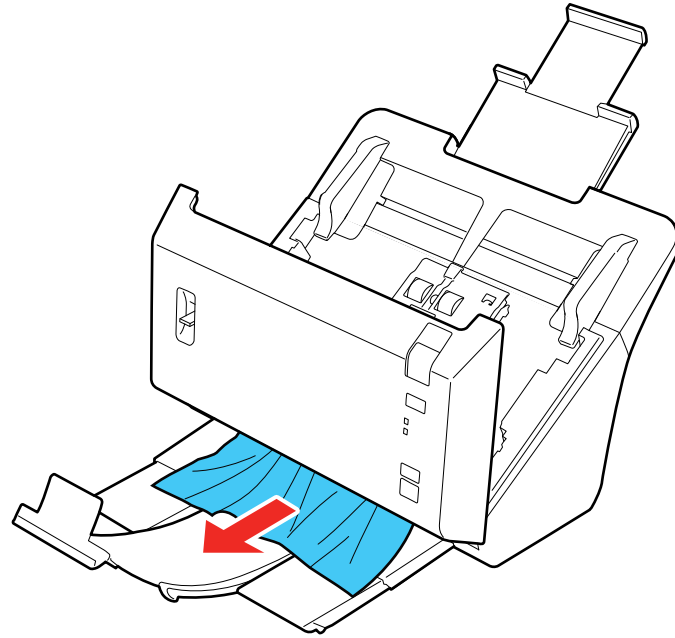

6. Close the scanner cover.
7. Carefully follow all loading instructions when you reload originals.

Parent topic: [Solving Scanning Problems](#)

Related tasks

[Loading Photos in the Input Tray](#)

[Loading Documents in the Input Tray](#)

[Loading Plastic Cards in the Input Tray](#)

[Loading Special Documents](#)

Scanning is Slow

If scanning becomes slow, try these solutions:

- Scan your original at a lower resolution, if possible.

- Make sure your system meets the requirements for your operating system. If you are scanning a high-resolution image, you may need more than the minimum requirements. If necessary, increase your system's memory or reduce the resolution.
- If you are running virus protection or other security software, exclude the TWAIN.log files from monitoring or set the TWAIN.log file as read only. See your virus protection or security software instructions for details. The TWAIN.log file is saved in C:\Users\\AppData\Local\Temp.

Note: You may need to unhide system folders to view files in that location.

Parent topic: [Solving Scanning Problems](#)

Related concepts

[Uninstall Your Scanner Software](#)

Solving Scanned Image Quality Problems

Check these sections if a scanned image on your computer screen has a quality problem.

[Image Consists of a Few Dots Only](#)

[Straight Lines in an Image Appear Crooked](#)

[Image is Distorted or Blurry](#)

[Image Colors are Patchy at the Edges](#)

[Image is Too Dark](#)

[Scanned Image Colors Do Not Match Original Colors](#)

[Back of Original Image Appears in Scanned Image](#)

[Scanned Characters are Blurry](#)

[Characters are not Recognized During Conversion to Editable Text \(OCR\)](#)

[Ripple Patterns Appear in an Image](#)

[Spots or Lines Appear in All Scanned Images](#)

[Streaks Appear in All Scanned Images](#)

[Scanned Image is Cropped](#)

[Resetting the Epson Scan 2 Settings](#)

Parent topic: [Solving Problems](#)

Image Consists of a Few Dots Only

If your scanned image consists only of a few dots, try these solutions:

- Make sure you placed your original for scanning facing the correct way.
- If the **Image Type** setting is **Black & White**, adjust the **Threshold** and scan again.

Parent topic: [Solving Scanned Image Quality Problems](#)

Straight Lines in an Image Appear Crooked

If straight lines in an original appear crooked in a scanned image, make sure to place your original straight when you scan it.

Parent topic: [Solving Scanned Image Quality Problems](#)

Related tasks

[Loading Documents in the Input Tray](#)

[Loading Photos in the Input Tray](#)

[Loading Special Documents](#)

Image is Distorted or Blurry

If a scanned image appears distorted or blurry, try these solutions:

- Make sure your original is not wrinkled or warped. This may prevent the original from laying flat when passed over the scanner sensors.
- Do not move your original or your product during scanning.
- Your product will not operate properly while tilted at an angle. Place your product on a flat, stable surface that extends beyond its base in all directions.
- Adjust these Epson Scan 2 settings (if available) and try scanning again:
 - Increase the **Resolution** setting.
 - If the **Image Type** setting is **Black & White**, adjust the **Threshold** setting.
 - If the **Image Type** setting is **Color** or **Grayscale**, select the **Unsharp Mask** setting.
 - If the **Image Type** setting is **Black & White**, select **Text Enhancement**. If the **Image Type** setting is **Color** or **Grayscale**, change the **Text Enhancement** setting to **High**.

Parent topic: [Solving Scanned Image Quality Problems](#)

Related references

[Additional Scanning Settings - Main Settings Tab](#)

Image Colors are Patchy at the Edges

If you are scanning a thick or warped original, cover its edges with paper to block external light as you scan it.

Parent topic: [Solving Scanned Image Quality Problems](#)

Related tasks

[Loading Special Documents](#)

Image is Too Dark

If your scanned image is too dark, try these solutions:

- If the **Image Type** is set to **Color** or **Grayscale**, adjust the **Brightness** setting.
- Check the brightness and contrast settings of your computer monitor.

Parent topic: [Solving Scanned Image Quality Problems](#)

Related references

[Additional Scanning Settings - Main Settings Tab](#)

[Additional Scanning Settings - Advanced Settings Tab](#)

Scanned Image Colors Do Not Match Original Colors

Printed colors can never exactly match the colors on your computer monitor because printers and monitors use different color systems: monitors use RGB (red, green, and blue) and printers typically use CMYK (cyan, magenta, yellow, and black).

Check the color matching and color management capabilities of your computer, display adapter, and the software you are using to see if they are affecting the palette of colors you see on your screen.

To adjust the colors in your scanned image, adjust these Epson Scan 2 settings (if available) and try scanning again:

- If the **Image Type** setting is **Color** or **Grayscale**, adjust the **Contrast** setting.
- If the **Image Type** setting is **Black & White** or **Grayscale**, adjust the **Color Enhance** setting.

Parent topic: [Solving Scanned Image Quality Problems](#)

Back of Original Image Appears in Scanned Image

If an image from the back of a thin original appears in your scanned image, try these solutions:

- Place a piece of black paper on the back of the original and scan it again.
- Adjust these Epson Scan 2 settings (if available) and try scanning again:
 - Select the **Advanced Settings** tab and adjust the **Brightness** setting.
 - If the **Image Type** is set to **Black & White**, select **Text Enhancement**. If the **Image Type** is set to **Color** or **Grayscale**, change the **Text Enhancement** setting to **High**.

Parent topic: [Solving Scanned Image Quality Problems](#)

Related references

[Additional Scanning Settings - Main Settings Tab](#)

[Additional Scanning Settings - Advanced Settings Tab](#)

Scanned Characters are Blurry

If characters in your scanned images are blurry, try these solutions:

- Make sure you do not move the scanner or original while scanning.
- Operate the scanner on a flat, stable surface.
- Adjust these Epson Scan 2 settings (if available) and try scanning again:
 - Select the **Text Enhancement** setting.
 - If the **Image Type** setting is **Black & White**, adjust the **Threshold** setting.
 - Increase the **Resolution** setting.
 - Set the **Image Type** to **Grayscale**.

Parent topic: [Solving Scanned Image Quality Problems](#)

Characters are not Recognized During Conversion to Editable Text (OCR)

If characters in your scanned images are not recognized during OCR conversion, try these solutions:

- Make sure your original is loaded straight on your product.
- Use an original with clear text.
- Adjust these Epson Scan 2 settings (if available) and try scanning again:
 - Select the correct **Image Type** setting.
 - Select or adjust the **Text Enhancement** setting.

- If the **Image Type** is set to **Black & White**, adjust the **Threshold** setting.
- Select the correct **Text Language** setting.
- Set the **Image Type** to **Grayscale**.
- Set the scanning resolution between 200 and 600 dpi.
- If the original document is in landscape mode, set the **Rotate** setting to **Auto** in Epson Scan 2.
- If you are using OCR software, check the manual for any additional adjustments.

Parent topic: [Solving Scanned Image Quality Problems](#)

Ripple Patterns Appear in an Image

You may see a ripple pattern (called a moiré) in scanned images of printed documents. This is caused by interference from differing pitches in the scanner's screen and your original's halftone screen. To reduce this effect, adjust these Epson Scan 2 settings (if available) and try scanning again:

- Select the **Descreening** setting.
- Select a lower **Resolution** setting.

Parent topic: [Solving Scanned Image Quality Problems](#)

Spots or Lines Appear in All Scanned Images

If spots or lines appear in all your scanned images, follow these steps to clean the scanner glass:

1. Turn off the scanner and unplug the AC adapter.
2. Disconnect any connected cables.

3. Pull down on the cover open lever and open the scanner cover.

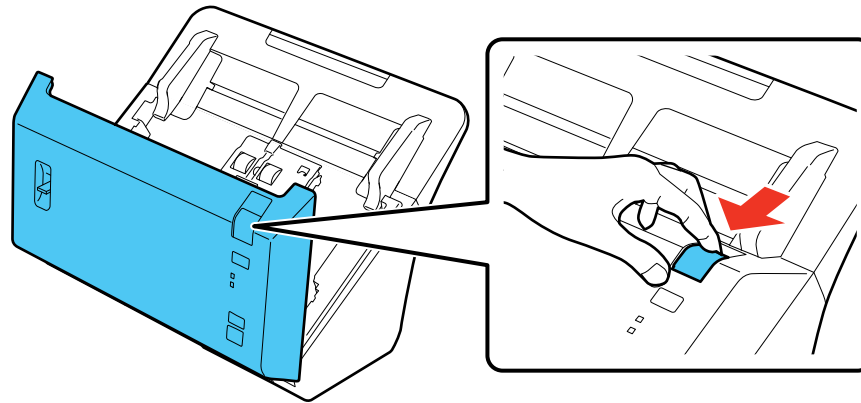

4. Wipe off any dust or dirt on the glass scanning surfaces using the included microfiber cloth or a soft, dry cloth.

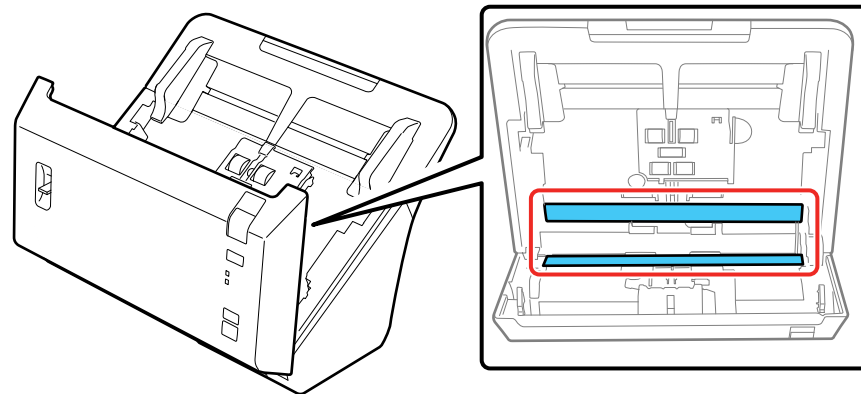

Note: If the glass surfaces are stained with grease or some other hard-to-remove material, use a small amount of glass cleaner on a soft cloth to remove it. Wipe off all remaining liquid.

Caution: Do not spray glass cleaner directly on the scanning surfaces. Be careful not to place too much force on the glass.

5. Close the scanner cover.
6. Plug in the AC adapter and turn on the scanner.

Note: If lines persist in your photo scans, select **Settings > Scan Settings > Reduce lines and streaks** and select **On** in the FastFoto software.

Parent topic: [Solving Scanned Image Quality Problems](#)

Related tasks

[Cleaning Inside Your Scanner](#)

Streaks Appear in All Scanned Images

If streaks appear in all your scanned images, try these solutions:

- Clean the glass surfaces inside your scanner using a genuine Epson cleaning kit or the microfiber cloth that came with your scanner.
- The Epson FastFoto software can automatically correct any vertical lines in scanned images. Click **Settings > Advanced Settings** and click the **Reduce lines and streaks** checkbox.

Note: Not all lines can be corrected.

- Keep the scanner cover closed when it is not in use to prevent dirt or dust from getting inside.

Parent topic: [Solving Scanned Image Quality Problems](#)

Related references

[Available Epson FastFoto Preferences and Features](#)

Scanned Image is Cropped

If the edges of a scanned image are cropped, try the following solutions:

- Select **Auto Detect** as the Document Size setting in Epson Scan 2, Document Capture Pro, or Document Capture.
- In Epson Scan 2, select the **Main Settings** tab. Select **Document Size > Settings** and adjust the cropping area shown in the **Crop Margins for Size "Auto"** setting.
- **Document Capture Pro (Windows):** Select **Detailed Settings** from the Scan window. Select **Document Size > Settings** and then adjust the cropping area shown in the **Crop Margins for Size "Auto"** setting.

- **Document Capture Pro (Windows):** Select **Scan Settings > Detailed Settings** from the Scan window. Select **Document Size** and then select the **Auto Detect** setting.
- **Document Capture (Mac):** Click the  Scan button and select **Main Settings** from the Scan window. Select **Document Size** and then adjust the cropping area shown in the **Crop Margins for Size "Auto"** setting.

Parent topic: [Solving Scanned Image Quality Problems](#)



Related references

[Additional Scanning Settings - Main Settings Tab](#)

[Additional Scanning Settings - Advanced Settings Tab](#)

Resetting the Epson Scan 2 Settings

If you continue to experience image quality problems after trying all possible solutions, you may need to reset the Epson Scan 2 settings using the Epson Scan 2 Utility.

1. Do one of the following to start the Epson Scan 2 Utility:
 - **Windows 10:** Click  > **EPSON > Epson Scan 2 Utility.**
 - **Windows 8.x:** Navigate to the **Apps** screen and select **Epson Scan 2 Utility.**
 - **Windows (other versions):** Click  or **Start**, and select **All Programs** or **Programs**. Select **EPSON > Epson Scan 2 > Epson Scan 2 Utility.**
 - **Mac:** Open the **Applications** folder, open the **Epson Software** folder, and select **Epson Scan 2 Utility.**
2. Click the **Other** tab.
3. Click **Reset**.

Note: If resetting the Epson Scan 2 settings does not solve your problem, uninstall Epson Scan 2 and re-install it.

Parent topic: [Solving Scanned Image Quality Problems](#)

Uninstall Your Scanner Software

If you have a problem that requires you to uninstall and re-install your software, follow the instructions for your operating system.



[Uninstalling Scanner Software - Windows](#)

Uninstalling Scanner Software - Mac

Parent topic: [Solving Problems](#)

Uninstalling Scanner Software - Windows

You can uninstall and then re-install your scanner software to solve certain problems.

1. Turn off the scanner.
2. Disconnect any interface cables.
3. Do the following to uninstall each of your scanning software programs and follow any on-screen instructions:
 - **Windows 10:** Click  and select  (Settings) > **Apps > Apps & features**. Select the scanner software program and click **Uninstall**.
 - **Windows 8.x:** Navigate to the **Apps** screen and select **Control Panel > Programs > Programs and Features**. Select the scanner software program and click **Uninstall/Change**.
 - **Windows 7 or Windows Vista:** Open the Windows **Control Panel** utility. Select **Programs and Features**. (In Classic view, select **Programs** and click **Uninstall a program**.) Select the scanner software program and click **Uninstall/Change**.
4. Restart your computer, then see the *Start Here* sheet to re-install your software.

Note: If you find that re-installing your scanner software does not solve a problem, contact Epson.

Parent topic: [Uninstall Your Scanner Software](#)

Uninstalling Scanner Software - Mac

In most cases, you do not need to uninstall your scanner software before re-installing it. However, you can download the Uninstaller utility from the Epson support website to uninstall your scanner software as described here.

1. To download the Uninstaller utility, visit epson.com/support (U.S.), epson.ca/support (Canada), or epson.com.jm/support (Caribbean) and select your product.
2. Follow the instructions on the screen to install the Uninstaller utility.
3. Quit all applications currently running on your Mac.
4. Double-click the **Uninstaller** icon.
5. In the Epson Uninstaller screen, select the checkbox for each software program you want to uninstall.

6. Click **Uninstall**.
7. Follow the on-screen instructions to uninstall the software.
8. To reinstall your scanner software, see the *Start Here* sheet for instructions.

Note: If you find that re-installing your scanner software does not solve a problem, contact Epson.

Parent topic: [Uninstall Your Scanner Software](#)

Where to Get Help

If you need to contact Epson for technical support services, use the following support options.

Internet Support

Visit Epson's support website at epson.com/support (U.S.), epson.ca/support (Canada), or epson.com.jm/support (Caribbean) and select your product for solutions to common problems with your product. You can download utilities and documentation, get FAQs and troubleshooting advice, or e-mail Epson with your questions.

Speak to a Support Representative

Before you call Epson for support, please have the following information ready:

- Product name
- Product serial number (located on a label on the product)
- Proof of purchase (such as a store receipt) and date of purchase
- Computer configuration
- Description of the problem

Then call:

- U.S.: (562) 276-4382, 6 AM to 8 PM, Pacific Time, Monday through Friday, and 7 AM to 4 PM, Pacific Time, Saturday
- Canada: (905) 709-3839, 6 AM to 8 PM, Pacific Time, Monday through Friday, and 7 AM to 4 PM, Pacific Time, Saturday

Days and hours of support are subject to change without notice. Toll or long distance charges may apply.

Note: For help using any other software on your system, see the documentation for that software for technical support.

Purchase Supplies and Accessories

You can purchase genuine Epson accessories at epson.com (U.S. sales), epson.ca (Canadian sales), or epson.com.jm (Caribbean sales). You can also purchase accessories from an Epson authorized reseller. To find the nearest one, call 800-GO-EPSON (800-463-7766) in the U.S. or 800-807-7766 in Canada.

Parent topic: [Solving Problems](#)

Technical Specifications

These sections list the technical specifications for your scanner.

Note: Epson offers a recycling program for end of life Epson products. Please go to [this site](#) (U.S) or [this site](#) (Canada) for information on how to return your Epson products for proper disposal.

[Windows System Requirements](#)

[Mac System Requirements](#)

[General Specifications](#)

[Dimension Specifications](#)

[Electrical Specifications](#)

[Environmental Specifications](#)

[USB Interface Specifications](#)

[Safety and Approvals Specifications](#)

Windows System Requirements

Make sure your system meets these requirements before using it with your scanner.

System	Microsoft Windows 10, Windows 8.x, Windows 7
Interface	External USB port (Type A)
Display	Color monitor with 1024 x 768 resolution or higher, and 24-bit color (Full Color)

Note: For the latest product software available for your operating system, visit the Epson support site at [epson.com/support](#) (U.S.), [epson.ca/support](#) (Canada), or [epson.com.jm/support](#) (Caribbean), select your product, and select **Downloads**.

Parent topic: [Technical Specifications](#)

Mac System Requirements

Make sure your system meets these requirements before using it with your scanner.

System	macOS 10.13.x, 10.12.x OS X 10.11.x, 10.10.x, 10.9.x
	Note: The FastFoto 2.0 software requires macOS 10.13.x, macOS 10.12.x or OS X 10.11.x.
	(Fast user switching on Mac OS X is not supported.)
Interface	Macintosh USB
Display	Color monitor with 1024 × 768 resolution or higher

Note: Epson Scan 2 does not support the UNIX File System (UFS) for OS X. Install Epson Scan 2 on a disk or in a partition that does not use UFS.

Parent topic: [Technical Specifications](#)

General Specifications

Scanner type	Sheet feed, one pass duplex, color
Photoelectric device	1 line CMOS Contact Image Sensor (CIS)
Effective pixels	5100 × 8400 pixels at 600 dpi
Document size	Paper: Maximum: 8.5 × 120 inches (215.9 × 3048 mm) Minimum: 2 × 2 inches (50.8 × 50.8 mm) Photos: Maximum: 8 × 10 inches (203.2 × 254 mm) Minimum: 3 × 5 inches (76.2 × 127 mm)
Paper input	Facedown loading
Paper output	Facedown ejection
Paper capacity	80 sheets of paper at 21 lb (80 g/m ²) weight 30 photos less than .009 inches (.23 mm) thick each

Scanning resolution	600 dpi (main scan) 600 dpi with Micro Step (sub scan)
Output resolution	75 to 1200 dpi (in 1 dpi increments)
Image data	16 bits per pixel per color internal 1 to 8 bits per pixel per color external
Interface	One Hi-Speed USB port
Light source	RGB LED

Parent topic: [Technical Specifications](#)

Dimension Specifications

Height	8.07 inches (205 mm)
Width	11.8 inches (300 mm)
Depth	8.66 inches (220 mm)
Weight	approximately 8.8 lb (4 kg)

Note: Dimensions do not include projecting parts.

Parent topic: [Technical Specifications](#)

Electrical Specifications

Scanner

Note: Check the label on the scanner and the AC adapter for voltage information. Power consumption varies depending on operating conditions or whether an option is installed.

Rated input voltage	DC 24 V
Rated input current	2 A
Rated input frequency	50 to 60 Hz

Power consumption Operating: 42 W
Ready mode: 8 W
Sleep mode: 1.6 W
Power off mode: 0.4 W

AC Adapter

AC adapter model A421H
Rated input voltage AC 100 to 240 V
Rated input current AC 1.20 A
Rated input frequency 50 to 60 Hz
Rated output voltage DC 24 V
Rated output current 2 A

Parent topic: [Technical Specifications](#)

Environmental Specifications

Temperature Operating: 41 to 95 °F (5 to 35 °C)
Storage: –13 to 140 °F (–25 to 60 °C)

Humidity Operating: 10 to 80% RH
(non-condensing) Storage: 10 to 85% RH

Operating conditions Ordinary office or home conditions

Note: Avoid operating the scanner in direct sunlight, near a strong light source, or in extremely dusty conditions.

Caution: Some photo papers become extremely sticky in hot and humid environments and cannot be scanned.

Parent topic: [Technical Specifications](#)

USB Interface Specifications

Interface type	Universal Serial Bus Specifications Revision 2.0
Electrical standard	Full Speed mode (12 Mbits per second) and Hi-Speed mode (480 Mbits per second) of Universal Serial Bus Specifications Revision 2.0
Connector type	One Type B port

Parent topic: [Technical Specifications](#)

Safety and Approvals Specifications

Scanner

United States	EMC: FCC part 15 Subpart B class B
Canada	EMC: CAN/CSA-CEI/IEC CISPR 22 Class B

AC Adapter

United States	Safety: UL60950-1 EMC: FCC part 15 Subpart B class B
Canada	Safety: CAN/CSA C22.2 No. 60950-1 EMC: CAN/CSA-CEI/IEC CISPR 22 Class B

Parent topic: [Technical Specifications](#)

Notices

Check these sections for important notices about your scanner.

Note: Epson offers a recycling program for end of life Epson products. Please go to [this site](#) (U.S) or [this site](#) (Canada) for information on how to return your Epson products for proper disposal.

[Important Safety Instructions](#)

[Restrictions on Copying](#)

[Default Delay Times for Power Management for Epson Products](#)

[Binding Arbitration and Class Waiver](#)

[Trademarks](#)

[FCC Compliance Statement](#)

[Copyright Notice](#)

Important Safety Instructions

Follow these safety instructions when setting up and using the scanner:

- Read all these instructions, and follow all warnings and instructions marked on the scanner.
- Place the scanner close enough to the computer for the interface cable to reach it easily.
- Do not use with wet hands.
- When connecting this product to a computer or other device with a cable, ensure the correct orientation of the connectors. Each connector has only one correct orientation. Inserting a connector in the wrong orientation may damage both devices connected by the cable.
- Do not insert objects into any opening as they may touch dangerous voltage points or short out parts. Beware of electrical shock hazards.
- Place the product on a flat, stable surface that extends beyond the base of the product in all directions. If you place the product by the wall, leave at least 3.9 inches (10 cm) between the back of the product and the wall. The product will not operate properly if it is tilted at an angle.
- After replacing consumable parts, dispose of them correctly following the rules of your local authority. Do not disassemble them.
- Do not repeatedly scan the same photo. Scanning photos multiple times can cause the photos to stick together due to a buildup of static electricity and could potentially damage the photos.

- Do not place or store the scanner outdoors, in a car, near excessive dirt or dust, water, heat sources, or in locations subject to shocks, vibrations, condensation, high temperature or humidity, direct sunlight, strong light sources, or rapid changes in temperature or humidity.
- Never disassemble, modify, or attempt to repair the scanner or a scanner option by yourself except as specifically explained in this guide.

AC Adapter

- Do not place or store the AC adapter outdoors, in a car, near excessive dirt or dust, water, heat sources, or in locations subject to shocks, vibrations, condensation, high temperature or humidity, direct sunlight, strong light sources, or rapid changes in temperature or humidity.
- Place the scanner and the AC adapter near an electrical outlet where the adapter can be easily unplugged.
- The AC power cord should be placed to avoid abrasions, cuts, fraying, crimping, and kinking.
- Do not place objects on top of the AC power cord and do not allow the AC adapter or the power cord to be stepped on or run over. Be particularly careful to keep the AC power cord straight at the end and the point where it enters the AC adapter.
- Use only the AC adapter that comes with your scanner. Using any other adapter could cause fire, electrical shock, or injury.
- Use only the power cord that comes with your scanner. Use of another cord may cause fires or shock. Do not use the cord with any other equipment.
- The AC adapter is designed for use with the scanner with which it was included. Do not attempt to use it with other electronic devices unless specified.
- Use only the type of power source indicated on the AC adapter's label, and always supply power directly from a standard domestic electrical outlet with the AC adapter that meets the relevant local safety standards.
- Avoid using outlets on the same circuit as photocopiers or air control systems that regularly switch on and off.
- If you use an extension cord with the scanner, make sure the total ampere rating of the devices plugged into the extension cord does not exceed the cord's ampere rating. Also, make sure the total ampere rating of all devices plugged into the wall outlet does not exceed the wall outlet's ampere rating.
- Never disassemble, modify, or attempt to repair the AC adapter by yourself except as specifically explained in the scanner's guides.
- If damage occurs to the plug, replace the cord set or consult a qualified electrician. If there are fuses in the plug, make sure you replace them with fuses of the correct size and rating.

- Unplug the scanner and the AC adapter, and refer servicing to qualified service personnel under the following conditions: The AC adapter or plug is damaged; liquid has entered the scanner or the AC adapter; the scanner or the AC adapter has been dropped or the case has been damaged; the scanner or the AC adapter does not operate normally or exhibits a distinct change in performance. (Do not adjust controls that are not covered by the operating instructions.)
- Unplug the scanner and the AC adapter before cleaning. Clean with a damp cloth only. Do not use liquid or aerosol cleaners.
- If you are not going to use the scanner for a long period, be sure to unplug the AC adapter from the electrical outlet.

Parent topic: [Notices](#)

Restrictions on Copying

Observe the following restrictions to ensure responsible and legal use of your scanner.

Copying of the following items is prohibited by law:

- Bank bills, coins, government-issued marketable securities, government bond securities, and municipal securities
- Unused postage stamps, pre-stamped postcards, and other official postal items bearing valid postage
- Government-issued revenue stamps, and securities issued according to legal procedure

Exercise caution when copying the following items:

- Private marketable securities (stock certificates, negotiable notes, checks, etc.), monthly passes, concession tickets, etc.
- Passports, driver's licenses, warrants of fitness, road passes, food stamps, tickets, etc.

Note: Copying these items may also be prohibited by law.

Restriction on disassembling and decompiling

You may not disassemble, decompile, or otherwise attempt to derive the source code of any software included with this product.

Parent topic: [Notices](#)

Default Delay Times for Power Management for Epson Products

This product will enter sleep mode after a period of nonuse. This is to ensure that the product meets Energy Star standards of energy efficiency. More energy savings can be achieved by setting the time to sleep to a shorter interval.

Parent topic: [Notices](#)

Binding Arbitration and Class Waiver

1. DISPUTES, BINDING INDIVIDUAL ARBITRATION, AND WAIVER OF CLASS ACTIONS AND CLASS ARBITRATIONS

1.1 Disputes. The terms of this Section 1 shall apply to all Disputes between you and Epson. The term "Dispute" is meant to have the broadest meaning permissible under law and includes any dispute, claim, controversy or action between you and Epson arising out of or relating to this Agreement, Epson branded products (hardware and including any related software), or other transaction involving you and Epson, whether in contract, warranty, misrepresentation, fraud, tort, intentional tort, statute, regulation, ordinance, or any other legal or equitable basis. "DISPUTE" DOES NOT INCLUDE IP CLAIMS, or more specifically, a claim or cause of action for (a) trademark infringement or dilution, (b) patent infringement, (c) copyright infringement or misuse, or (d) trade secret misappropriation (an "IP Claim"). You and Epson also agree, notwithstanding Section 1.6, that a court, not an arbitrator, may decide if a claim or cause of action is for an IP Claim.

1.2 Binding Arbitration. You and Epson agree that all Disputes shall be resolved by binding arbitration according to this Agreement. **ARBITRATION MEANS THAT YOU WAIVE YOUR RIGHT TO A JUDGE OR JURY IN A COURT PROCEEDING AND YOUR GROUNDS FOR APPEAL ARE LIMITED.**

Pursuant to this Agreement, binding arbitration shall be administered by JAMS, a nationally recognized arbitration authority, pursuant to its code of procedures then in effect for consumer related disputes, but excluding any rules that permit joinder or class actions in arbitration (for more detail on procedure, see Section 1.6 below). You and Epson understand and agree that (a) the Federal Arbitration Act (9 U.S.C. §1, et seq.) governs the interpretation and enforcement of this Section 1, (b) this Agreement memorializes a transaction in interstate commerce, and (c) this Section 1 shall survive termination of this Agreement.

1.3 Pre-Arbitration Steps and Notice. Before submitting a claim for arbitration, you and Epson agree to try, for sixty (60) days, to resolve any Dispute informally. If Epson and you do not reach an agreement to resolve the Dispute within the sixty (60) days, you or Epson may commence an arbitration. Notice to Epson must be addressed to: Epson America, Inc., ATTN: Legal Department, 3840 Kilroy Airport Way, Long Beach, CA 90806 (the "Epson Address"). The Dispute Notice to you will be sent to the most recent address Epson has in its records for you. For this reason, it is important to notify us if your address changes by emailing us at EAILEgal@ea.epson.com or writing us at the Epson Address above. Notice of the Dispute shall include the sender's name, address and contact information, the facts giving rise to the

Dispute, and the relief requested (the "Dispute Notice"). Following receipt of the Dispute Notice, Epson and you agree to act in good faith to resolve the Dispute before commencing arbitration.

1.4 Small Claims Court. Notwithstanding the foregoing, you may bring an individual action in the small claims court of your state or municipality if the action is within that court's jurisdiction and is pending only in that court.

1.5 WAIVER OF CLASS ACTIONS AND CLASS ARBITRATIONS. YOU AND EPSON AGREE THAT EACH PARTY MAY BRING DISPUTES AGAINST THE OTHER PARTY ONLY IN AN INDIVIDUAL CAPACITY, AND NOT AS A PLAINTIFF OR CLASS MEMBER IN ANY CLASS OR REPRESENTATIVE PROCEEDING, INCLUDING WITHOUT LIMITATION FEDERAL OR STATE CLASS ACTIONS, OR CLASS ARBITRATIONS. CLASS ACTION LAWSUITS, CLASS-WIDE ARBITRATIONS, PRIVATE ATTORNEY-GENERAL ACTIONS, AND ANY OTHER PROCEEDING WHERE SOMEONE ACTS IN A REPRESENTATIVE CAPACITY ARE NOT ALLOWED. ACCORDINGLY, UNDER THE ARBITRATION PROCEDURES OUTLINED IN THIS SECTION, AN ARBITRATOR SHALL NOT COMBINE OR CONSOLIDATE MORE THAN ONE PARTY'S CLAIMS WITHOUT THE WRITTEN CONSENT OF ALL AFFECTED PARTIES TO AN ARBITRATION PROCEEDING.

1.6 Arbitration Procedure. If you or Epson commences arbitration, the arbitration shall be governed by the rules of JAMS that are in effect when the arbitration is filed, excluding any rules that permit arbitration on a class or representative basis (the "JAMS Rules"), available at <http://www.jamsadr.com> or by calling 1-800-352-5267, and under the rules set forth in this Agreement. All Disputes shall be resolved by a single neutral arbitrator, and both parties shall have a reasonable opportunity to participate in the selection of the arbitrator. The arbitrator is bound by the terms of this Agreement. The arbitrator, and not any federal, state or local court or agency, shall have exclusive authority to resolve all disputes arising out of or relating to the interpretation, applicability, enforceability or formation of this Agreement, including any claim that all or any part of this Agreement is void or voidable. Notwithstanding this broad delegation of authority to the arbitrator, a court may determine the limited question of whether a claim or cause of action is for an IP Claim, which is excluded from the definition of "Disputes" in Section 1.1 above. The arbitrator shall be empowered to grant whatever relief would be available in a court under law or in equity. The arbitrator may award you the same damages as a court could, and may award declaratory or injunctive relief only in favor of the individual party seeking relief and only to the extent necessary to provide relief warranted by that party's individual claim. In some instances, the costs of arbitration can exceed the costs of litigation and the right to discovery may be more limited in arbitration than in court. The arbitrator's award is binding and may be entered as a judgment in any court of competent jurisdiction.

You may choose to engage in arbitration hearings by telephone. Arbitration hearings not conducted by telephone shall take place in a location reasonably accessible from your primary residence, or in Orange County, California, at your option.

a) Initiation of Arbitration Proceeding. If either you or Epson decides to arbitrate a Dispute, both parties agree to the following procedure:

(i) Write a Demand for Arbitration. The demand must include a description of the Dispute and the amount of damages sought to be recovered. You can find a copy of a Demand for Arbitration at <http://www.jamsadr.com> ("Demand for Arbitration").

(ii) Send three copies of the Demand for Arbitration, plus the appropriate filing fee, to: JAMS, 500 North State College Blvd., Suite 600 Orange, CA 92868, U.S.A.

(iii) Send one copy of the Demand for Arbitration to the other party (same address as the Dispute Notice), or as otherwise agreed by the parties.

b) Hearing Format. During the arbitration, the amount of any settlement offer made shall not be disclosed to the arbitrator until after the arbitrator determines the amount, if any, to which you or Epson is entitled. The discovery or exchange of non-privileged information relevant to the Dispute may be allowed during the arbitration.

c) Arbitration Fees. Epson shall pay, or (if applicable) reimburse you for, all JAMS filings and arbitrator fees for any arbitration commenced (by you or Epson) pursuant to provisions of this Agreement.

d) Award in Your Favor. For Disputes in which you or Epson seeks \$75,000 or less in damages exclusive of attorney's fees and costs, if the arbitrator's decision results in an award to you in an amount greater than Epson's last written offer, if any, to settle the Dispute, Epson will: (i) pay you \$1,000 or the amount of the award, whichever is greater; (ii) pay you twice the amount of your reasonable attorney's fees, if any; and (iii) reimburse you for any expenses (including expert witness fees and costs) that your attorney reasonably accrues for investigating, preparing, and pursuing the Dispute in arbitration. Except as agreed upon by you and Epson in writing, the arbitrator shall determine the amount of fees, costs, and expenses to be paid by Epson pursuant to this Section 1.6d).

e) Attorney's Fees. Epson will not seek its attorney's fees and expenses for any arbitration commenced involving a Dispute under this Agreement. Your right to attorney's fees and expenses under Section 1.6d) above does not limit your rights to attorney's fees and expenses under applicable law; notwithstanding the foregoing, the arbitrator may not award duplicative awards of attorney's fees and expenses.

1.7 Opt-out. You may elect to opt-out (exclude yourself) from the final, binding, individual arbitration procedure and waiver of class and representative proceedings specified in this Agreement by sending a written letter to the Epson Address within thirty (30) days of your assent to this Agreement (including without limitation the purchase, download, installation of the Software or other applicable use of Epson Hardware, products and services) that specifies (i) your name, (ii) your mailing address, and (iii) your request to be excluded from the final, binding individual arbitration procedure and waiver of class and representative proceedings specified in this Section 1. In the event that you opt-out consistent with the procedure set forth above, all other terms shall continue to apply, including the requirement to provide notice prior to litigation.

1.8 Amendments to Section 1. Notwithstanding any provision in this Agreement to the contrary, you and Epson agree that if Epson makes any future amendments to the dispute resolution procedure and

class action waiver provisions (other than a change to Epson's address) in this Agreement, Epson will obtain your affirmative assent to the applicable amendment. If you do not affirmatively assent to the applicable amendment, you are agreeing that you will arbitrate any Dispute between the parties in accordance with the language of this Section 1 (or resolve disputes as provided for in Section 1.7, if you timely elected to opt-out when you first assented to this Agreement).

1.9 Severability. If any provision in this Section 1 is found to be unenforceable, that provision shall be severed with the remainder of this Agreement remaining in full force and effect. **The foregoing shall not apply to the prohibition against class or representative actions as provided in Section 1.5. This means that if Section 1.5 is found to be unenforceable, the entire Section 1 (but only Section 1) shall be null and void.**

Parent topic: [Notices](#)

Trademarks

EPSON® is a registered trademark, FastFoto is a trademark, and EPSON Exceed Your Vision is a registered logomark of Seiko Epson Corporation.

Mac and OS X are trademarks of Apple Inc, registered in the U.S. and other countries.

Windows is a registered trademark of Microsoft Corporation in the United States and/or other countries.

Google Drive is a trademark of Google LLC.

ABBYY and FineReader are registered trademarks of ABBYY Software, Ltd.

General Notice: Other product names used herein are for identification purposes only and may be trademarks of their respective owners. Epson disclaims any and all rights in those marks.



Parent topic: [Notices](#)

FCC Compliance Statement

For United States Users

This equipment has been tested and found to comply with the limits for a Class B digital device, pursuant to Part 15 of the FCC Rules. These limits are designed to provide reasonable protection against harmful interference in a residential installation. This equipment generates, uses, and can radiate radio frequency energy and, if not installed and used in accordance with the instructions, may cause harmful

interference to radio or television reception. However, there is no guarantee that interference will not occur in a particular installation. If this equipment does cause interference to radio and television reception, which can be determined by turning the equipment off and on, the user is encouraged to try to correct the interference by one or more of the following measures:

- Reorient or relocate the receiving antenna.
- Increase the separation between the equipment and receiver.
- Connect the equipment into an outlet on a circuit different from that to which the receiver is connected.
- Consult the dealer or an experienced radio/TV technician for help.

WARNING

The connection of a non-shielded equipment interface cable to this equipment will invalidate the FCC Certification or Declaration of this device and may cause interference levels which exceed the limits established by the FCC for this equipment. It is the responsibility of the user to obtain and use a shielded equipment interface cable with this device. If this equipment has more than one interface connector, do not leave cables connected to unused interfaces. Changes or modifications not expressly approved by the manufacturer could void the user's authority to operate the equipment.

For Canadian Users

CAN ICES-3(B)/NMB-3(B)

Parent topic: [Notices](#)

Copyright Notice

All rights reserved. No part of this publication may be reproduced, stored in a retrieval system, or transmitted in any form or by any means, electronic, mechanical, photocopying, recording, or otherwise, without the prior written permission of Seiko Epson Corporation. The information contained herein is designed only for use with this Epson product. Epson is not responsible for any use of this information as applied to other products.

Neither Seiko Epson Corporation nor its affiliates shall be liable to the purchaser of this product or third parties for damages, losses, costs, or expenses incurred by purchaser or third parties as a result of: accident, misuse, or abuse of this product or unauthorized modifications, repairs, or alterations to this product, or (excluding the U.S.) failure to strictly comply with Seiko Epson Corporation's operating and maintenance instructions.

Seiko Epson Corporation shall not be liable for any damages or problems arising from the use of any options or any consumable products other than those designated as Original Epson Products or Epson Approved Products by Seiko Epson Corporation.

Seiko Epson Corporation shall not be held liable for any damage resulting from electromagnetic interference that occurs from the use of any interface cables other than those designated as Epson approved Products by Seiko Epson Corporation.

This information is subject to change without notice.

[libTIFF Software Acknowledgment](#)

[libjpeg-turbo](#)

[A Note Concerning Responsible Use of Copyrighted Materials](#)

[Copyright Attribution](#)

Parent topic: [Notices](#)

libTIFF Software Acknowledgment

Copyright © 1988-1997 Sam Leffler

Copyright © 1991-1997 Silicon Graphics, Inc.

Permission to use, copy, modify, distribute, and sell this software and its documentation for any purpose is hereby granted without fee, provided that (i) the above copyright notices and this permission notice appear in all copies of the software and related documentation, and (ii) the names of Sam Leffler and Silicon Graphics may not be used in any advertising or publicity relating to the software without the specific, prior written permission of Sam Leffler and Silicon Graphics.

THE SOFTWARE IS PROVIDED "AS-IS" AND WITHOUT WARRANTY OF ANY KIND, EXPRESS, IMPLIED OR OTHERWISE, INCLUDING WITHOUT LIMITATION, ANY WARRANTY OF MERCHANTABILITY OR FITNESS FOR A PARTICULAR PURPOSE.

IN NO EVENT SHALL SAM LEFFLER OR SILICON GRAPHICS BE LIABLE FOR ANY SPECIAL, INCIDENTAL, INDIRECT OR CONSEQUENTIAL DAMAGES OF ANY KIND, OR ANY DAMAGES WHATSOEVER RESULTING FROM LOSS OF USE, DATA OR PROFITS, WHETHER OR NOT ADVISED OF THE POSSIBILITY OF DAMAGE, AND ON ANY THEORY OF LIABILITY, ARISING OUT OF OR IN CONNECTION WITH THE USE OR PERFORMANCE OF THIS SOFTWARE.

Parent topic: [Copyright Notice](#)

libjpeg-turbo

Copyright (C) 1991-2012 Thomas G. Lane, Guido Vollbeding

Copyright (C) 1999-2006 MIYASAKA Masaru

Copyright (C) 2009 Pierre Ossman for Cendio AB

Copyright (C) 2009-2013 D. R. Commander

Copyright (C) 2009-2011 Nokia Corporation and/or its subsidiary(-ies)

Redistribution and use in source and binary forms, with or without modification, are permitted provided that the following conditions are met:

- Redistributions of source code must retain the above copyright notice, this list of conditions and the following disclaimer.
- Redistributions in binary form must reproduce the above copyright notice, this list of conditions and the following disclaimer in the documentation and/or other materials provided with the distribution.
- Neither the name of the libjpeg-turbo Project nor the names of its contributors may be used to endorse or promote products derived from this software without specific prior written permission.

THIS SOFTWARE IS PROVIDED BY THE COPYRIGHT HOLDERS AND CONTRIBUTORS "AS IS", AND ANY EXPRESS OR IMPLIED WARRANTIES, INCLUDING, BUT NOT LIMITED TO, THE IMPLIED WARRANTIES OF MERCHANTABILITY AND FITNESS FOR A PARTICULAR PURPOSE ARE DISCLAIMED. IN NO EVENT SHALL THE COPYRIGHT HOLDERS OR CONTRIBUTORS BE LIABLE FOR ANY DIRECT, INDIRECT, INCIDENTAL, SPECIAL, EXEMPLARY, OR CONSEQUENTIAL DAMAGES (INCLUDING, BUT NOT LIMITED TO, PROCUREMENT OF SUBSTITUTE GOODS OR SERVICES; LOSS OF USE, DATA, OR PROFITS; OR BUSINESS INTERRUPTION) HOWEVER CAUSED AND ON ANY THEORY OF LIABILITY, WHETHER IN CONTRACT, STRICT LIABILITY, OR TORT (INCLUDING NEGLIGENCE OR OTHERWISE) ARISING IN ANY WAY OUT OF THE USE OF THIS SOFTWARE, EVEN IF ADVISED OF THE POSSIBILITY OF SUCH DAMAGE.

Parent topic: [Copyright Notice](#)

A Note Concerning Responsible Use of Copyrighted Materials

Epson encourages each user to be responsible and respectful of the copyright laws when using any Epson product. While some countries' laws permit limited copying or reuse of copyrighted material in certain circumstances, those circumstances may not be as broad as some people assume. Contact your legal advisor for any questions regarding copyright law.

Parent topic: [Copyright Notice](#)

Copyright Attribution

© 2018 Epson America, Inc.

9/18

CPD-50895R5

Parent topic: [Copyright Notice](#)