



# PDR Portable Desk Riser



### PDR SHIPPING SPECS

*Master Carton of 4 units*

<b>CARTON DIMENSIONS (H X D X W)</b>	21" x 12" x 8"
<b>WEIGHT</b>	28.5 LBS
<b>UPC PDR BLACK</b>	6-93285-00109-3
<b>UPC PDR WHITE</b>	6-93285-00108-6

- Premium compact design suitable for co-working spaces, travel, hotels & dorm rooms.
- Holds most laptops plus a mouse.
- 10" x 19" work surface.
- Rises to 15"; folds less than 1" thin.
- Weighs less than 7 lbs.
- Portable carry bag included.



# VADR

## Hi-Lift Adjustable Desk Riser



### VADR SHIPPING SPECS

<b>CARTON DIMENSIONS (H X D X W)</b>	34.5" x 20.2" x 6.5"
<b>WEIGHT</b>	31.52 LBS
<b>UPC VADR-B</b>	6-93285-00134-5
<b>UPC VADR-G</b>	6-93285-00135-2

- Large 31.5" x 17.25" work surface.
- EVR Enhanced Vertical Range from 4.3" to 19.7".
- Gas shock holds up to 30 lbs.
- Rear grommet for optional monitor arm.
- Full size 29" x 10" fixed keyboard tray.
- 10.5" wide slot holds tablet or phone.
- Easy-lift side handle.
- Quick disconnect keyboard tray allows portable use.
- Available in black or grey.



# ADR2

Adjustable Desk Riser with EVR

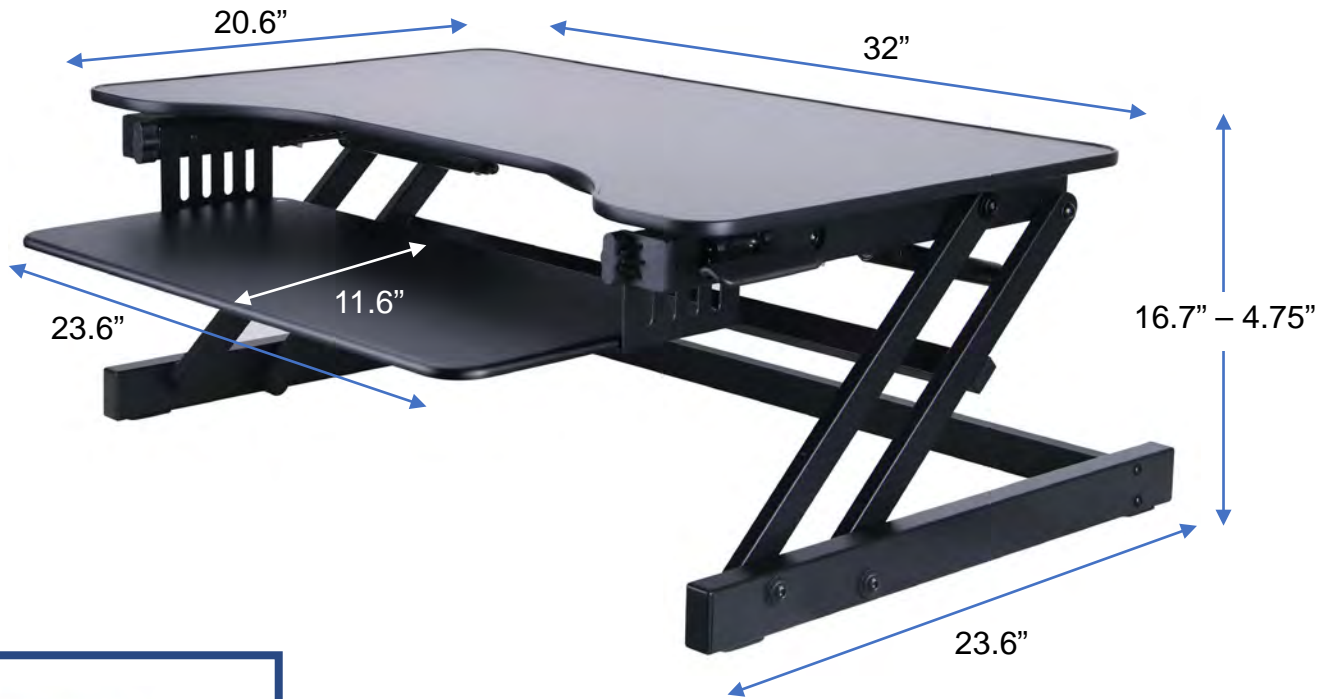

## ADR-2 SHIPPING SPECS

CARTON DIMENSIONS (H X D X W)	6.25" x 34.75" x 26"
WEIGHT	35.27 LBS
UPC ADR2-B	6-93285-00032-4
UPC ADR2-W	6-93285-00070-6
UPS ADR2-G	6-93285-00126-0

- EVR 20% greater Enhanced Vertical Range - rises up to 16.7" and lowers down to 4.75", to optimize the ergonomic work position for people of all heights.
- 32" top can hold 2 monitors or laptops.
- Large 32" x 20.5" work surface.
- Includes full size 24" x 11.5" ergonomic retractable keyboard tray - holds keyboard or laptop.
- Gas shocks lift up to 30 lbs.
- Fully assembled and ready to use.
- Available in black, white or grey





# DADR-2

## Deluxe Adjustable Desk Riser



### DADR-2 SHIPPING SPECS

<b>CARTON DIMENSIONS (H X D X W)</b>	6.5" x 40" x 26"
<b>WEIGHT</b>	45.25 LBS
<b>UPC DADR-2B</b>	6-93285-00034-8
<b>UPC DADR-2W</b>	6-93285-00078-2
<b>UPC DADR-2G</b>	6-93285-00127-7

- EVR 20% greater Enhanced Vertical Range - rises up to 17" and lowers down to 5", to optimize the ergonomic work position for people of all heights.
- 37.5" top can hold 2 monitors and a laptop.
- Large 37.5" x 20.5" work surface.
- Includes a full size 29" x 11.5" ergonomic retractable keyboard tray – can hold a keyboard or laptop.
- Includes a grommet hole for cable management, or to install a single or dual monitor arm.
- Gas shocks hold up to 35 lbs.
- Fully assembled and ready to use.
- Available in black, white and Grey



# EADR-2

Adjustable Desk Riser with EVR



## EADR-2 SHIPPING SPECS

<b>CARTON DIMENSIONS (H X D X W)</b>	7" x 34.5" x 23"
<b>WEIGHT</b>	38.25 LBS
<b>UPC EADR-2 BLACK</b>	6-93285-00071-3
<b>UPC EADR-2 WHITE</b>	6-93285-00072-0
<b>UPC EADR-2 TEAK</b>	6-93285-00125-3

- EVR Enhanced Vertical Range - rises up to 18" and lowers down to 5", to optimize the ergonomic work position for people of all heights.
- 32"W x 20.5"D top can hold 2 monitors or laptops.
- Straight up and down motion minimizes required depth (23").
- Includes an ergonomic retractable keyboard tray.
- Gas shocks hold up to 35 lbs.
- Grommet hole allows you to route cables or add an optional single or dual monitor arm.
- Fully assembled and ready to use.
- Available in black, white & teak



# DADR-40

## Adjustable Desk Riser with EVR



### DADR-40 SHIPPING SPECS

<b>CARTON DIMENSIONS (H X D X W)</b>	7" x 42.75" x 26.5"
<b>WEIGHT</b>	47.62 LBS
<b>UPC DADR-40 B</b>	6-93285-00091-1
<b>UPC DADR-40 W</b>	6-93285-00123-9
<b>UPC DADR-40 T</b>	6-93285-00122-2

- EVR Enhanced Vertical Range from 5" to 20".
- 40" wide desktop holds 2 large monitors, laptop, etc.
- Straight up and down motion minimizes required depth (23").
- Ergonomic retractable keyboard tray 25.5" x 11.25" will also hold a laptop if needed.
- Gas shocks hold up to 40 lbs.
- Rear grommet to route cables or add optional monitor arm (up to 2-monitor capacity).
- Works with optional floor stands DADR-FS2 or DADR-FSM to create a complete fixed or mobile standing desk.
- Fully assembled and ready to use.
- Monitor arm not included (see Rocelco DM1, DM2).
- Available in black, white or teak.





# DADR-46

## Adjustable Desk Riser with EVR



### DADR-46 SHIPPING SPECS

<b>CARTON DIMENSIONS (H X D X W)</b>	7.25" x 48.25" x 26.5"
<b>WEIGHT</b>	55.78 LBS
<b>UPC DADR-46 B</b>	6-93285-00092-8
<b>UPC DADR-46 T</b>	6-93285-00115-4
<b>UPC DADR-46 W</b>	6-93285-00124-6

- EVR Enhanced Vertical Range from 5" to 20".
- 46" extra-wide desktop holds up to 3 monitors, laptop etc.
- Straight up and down motion minimizes required depth (23").
- Ergonomic retractable keyboard tray 25.75" x 11.25" will also hold a laptop if needed.
- Gas shocks hold up to 45 lbs.
- Rear grommet to route cables or add optional monitor arm (up to 3-monitor capacity).
- Works with optional floor stands DADR-FS2 or DADR-FSM to create complete fixed or mobile standing desk.
- Fully assembled and ready to use.
- Monitor arm not included (see Rocelco DM1, DM2, DM3).
- Available in black, white or teak.



# DADR-46-AC-USB

46" wide Desk Riser with EVR plus 4AC+2USB outlets



## DADR-46-AC-USB SHIPPING SPECS

<b>CARTON DIMENSIONS HWD</b>	7.25" x 48.25" x 26.50"
<b>WEIGHT</b>	55.78 LBS
<b>UPC</b>	6-93285-00136-9

- EVR Enhanced Vertical Range from 5" to 20".
- 46" extra-wide desktop holds up to 3 monitors, laptop etc.
- Straight up and down motion minimizes required depth (23").
- Ergonomic retractable keyboard tray 25.75" x 11.25" will also hold a laptop if needed.
- Gas shocks hold up to 45 lbs.
- Rear grommet to route cables or add optional monitor arm (up to 3-monitor capacity).
- Works with optional floor stands DADR-FS2 or DADR-FSM to create complete fixed or mobile standing desk.
- Fully assembled and ready to use.
- Monitor arm not included (see Rocelco DM1, DM2, DM3).
- Includes 4AC outlets and 2 USB 2.0 ports on the desktop
- AC outlets 120V, 60Hz, 12A, UL listed.





# WS123

## Three Screen Workstation

*Triple monitor arm + hi-lift desk riser in one sleek package*



### WS123 SHIPPING SPECS

<b>CARTON DIMENSIONS (H X W X D)</b>	8.1" x 38.4" x 23"
<b>WEIGHT</b>	55.12 LBS
<b>UPC</b>	6-93285-00130-7

- Triple monitor arm combined with hi-lift desk riser in one sleek package - built from lightweight aluminum for hi-tech looks.
- 27.25" W x 19.75" D worktop offers EVR Enhanced Vertical Range from 1.5" to 19".
- Simple "light touch" counterbalanced height adjustment, requires minimal effort to pull up or push down, and stays put in any desired position - adjustable tension fine tunes to your setup.
- Articulating triple monitor arm offers 4.5" extra vertical adjustment range for optimized ergonomics – configures for three monitors up to 24", two monitors up to 27, or one monitor up to 32".
- Load rating up to 24 lbs (monitors included).
- Includes USB charging port & cable management system.
- Easy assembly with step-by-step instructions and online assembly video.



# DADR- FS2

## Desk Riser Floor Stand

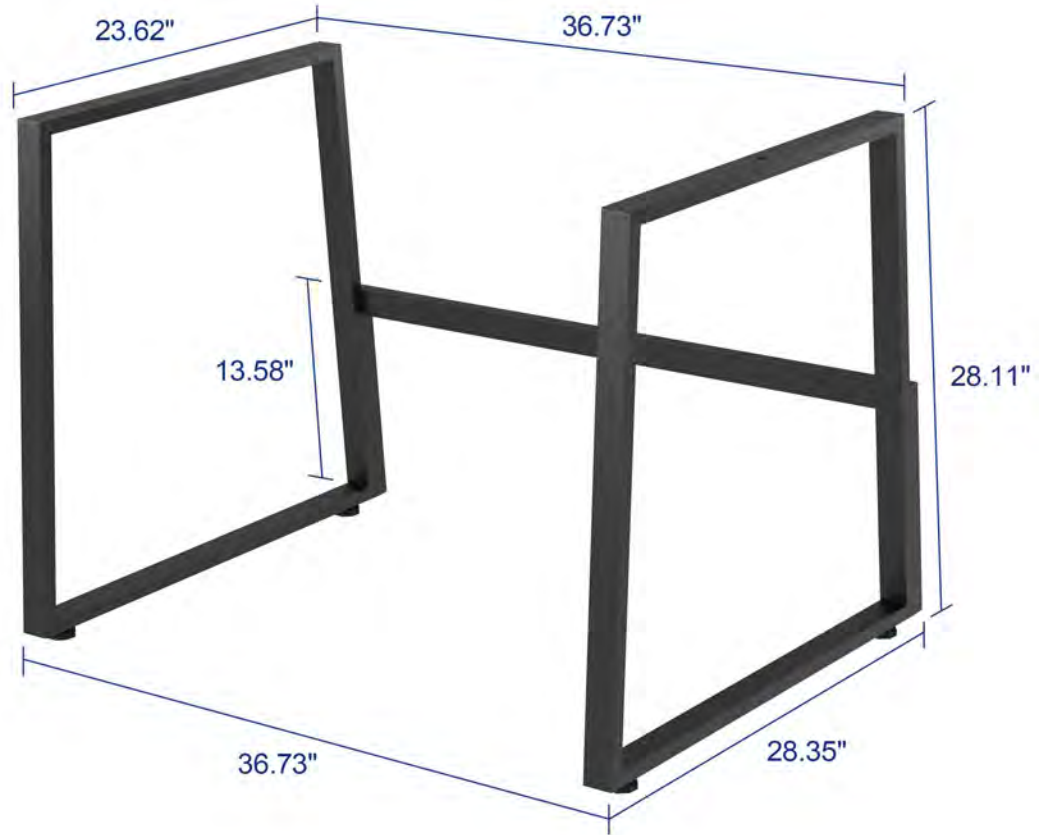

### DADR-FS2 SHIPPING SPECS

<b>CARTON DIMENSIONS (H X D X W)</b>	3.94" x 38.19" x 31.1"
<b>WEIGHT</b>	19.62 LBS
<b>UPC</b>	6-93285-00128-4

- Heavy duty floor stand converts your DADR-40 or DADR-46 desk riser into a complete Sit-to-Stand Desk.
- Get all the health and productivity benefits of a complete height adjustable standing desk, for a very cost-effective price.
- Mounting your DADR-40 or DADR-46 desk riser on the Floor Stand frees up space on your current desk.
- Mounting hardware and leveling feet included for easy 5-minute assembly and adjustment.
- Desk riser and monitor mounts not included.



# DADR-FSM

Mobile Floor Stand for DADR-40 / DADR-46

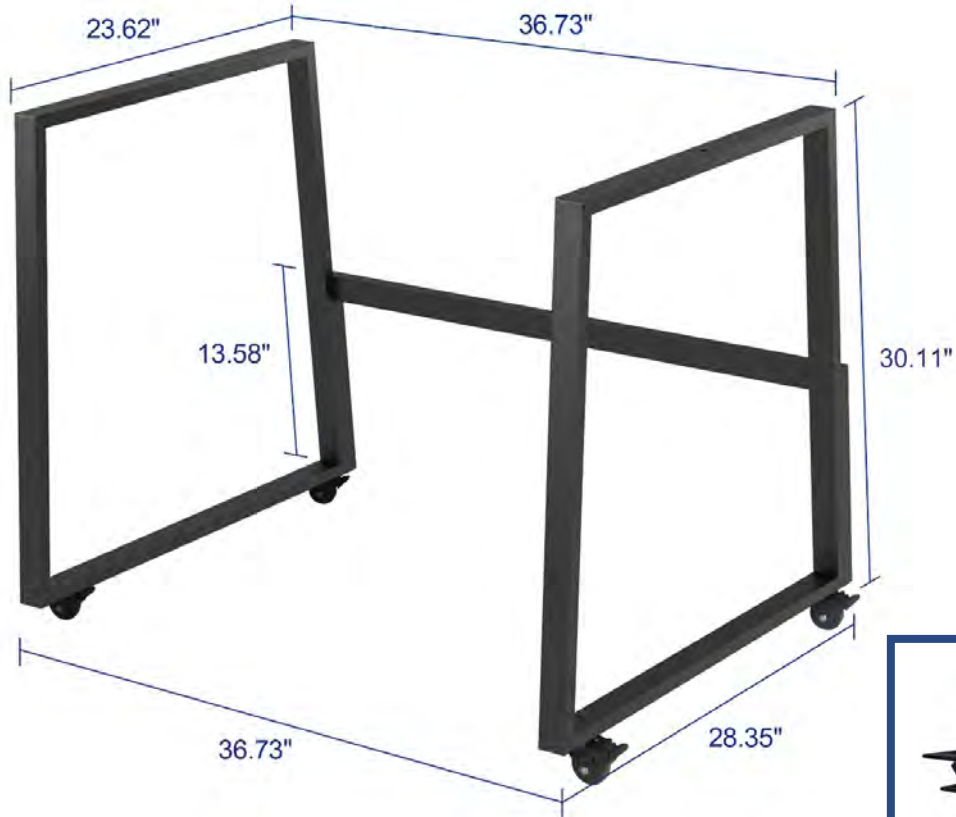

## DADR-FSM SHIPPING SPECS

<b>CARTON DIMENSIONS (H X D X W)</b>	<b>3.74" x 38.39" x 30.91"</b>
<b>WEIGHT</b>	<b>20.5 LBS</b>
<b>UPC</b>	<b>6-93285-00129-1</b>

- Create a rolling mobile standing desk workstation with Rocelco DADR-40 or DADR-46 desk riser (sold separately).
- Rugged heavy duty steel construction provides a stable, solid mobile standing desk.
- Commercial grade locking casters and optional stationary leveling feet included.
- Easy 5-minute assembly and quick-connect/disconnect thumbwheel system to mount DADR-40 or DADR-46 desk riser.





# CADR-46

## Corner Adjustable Desk Riser

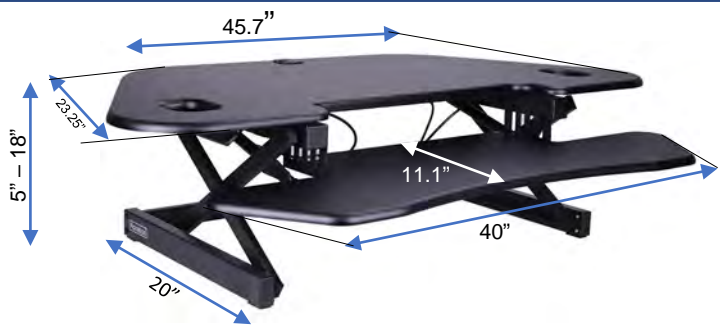

### CADR-46 SHIPPING SPECS

<b>CARTON DIMENSIONS (H X D X W)</b>	7.5" x 48.5" x 25.75"
<b>WEIGHT</b>	50 LBS
<b>UPC CADR-46 B</b>	6-93285-00090-4
<b>UPC CADR-46 T</b>	6-93285-00114-7

- EVR Enhanced Vertical Range - rises to 18" and lowers down to 5", to optimize the ergonomic work position for people of all heights.
- Optimizes the space on a corner desk or in a cubicle.
- Extra-wide 46" wide top can hold up to 3 monitors, a laptop, and more.
- Straight up and down motion minimizes required depth (23").
- Keyboard tray attaches in seconds and you're ready to go.
- Gas shocks hold up to 40 lbs.
- Grommet hole allows you to route cables or add an optional monitor desk mount (up to 3-monitor capacity).
- Available in black or teak.



# MSD-28

## Mobile Standing School Desk



### MSD-28 SHIPPING SPECS

<b>CARTON DIMENSIONS (H X D X W)</b>	30.75" x 23" x 8"
<b>WEIGHT</b>	42.33 LBS
<b>UPC</b>	6-93285-00119-2

- Gas spring motion assist with side handles for easy height adjustment from 25.5" to 42" above floor, to optimize the ergonomic position for students of all heights.
- Helps kids concentrate while staying more physically active & less fidgety/restless.
- Stable, durable & versatile design is perfect for classroom or homeschool use.
- Attractive woodgrain desktop 28" wide x 20" depth with 20 lb. load rating - easily holds a laptop + monitor + books, etc.
- 2" lockable casters provide easy mobility & also function as stationary feet when locked - use it anywhere at school or home.
- Optional MSD-BB book box fits under desktop.



# MSD-BB

## Optional Book Box for MSD-28

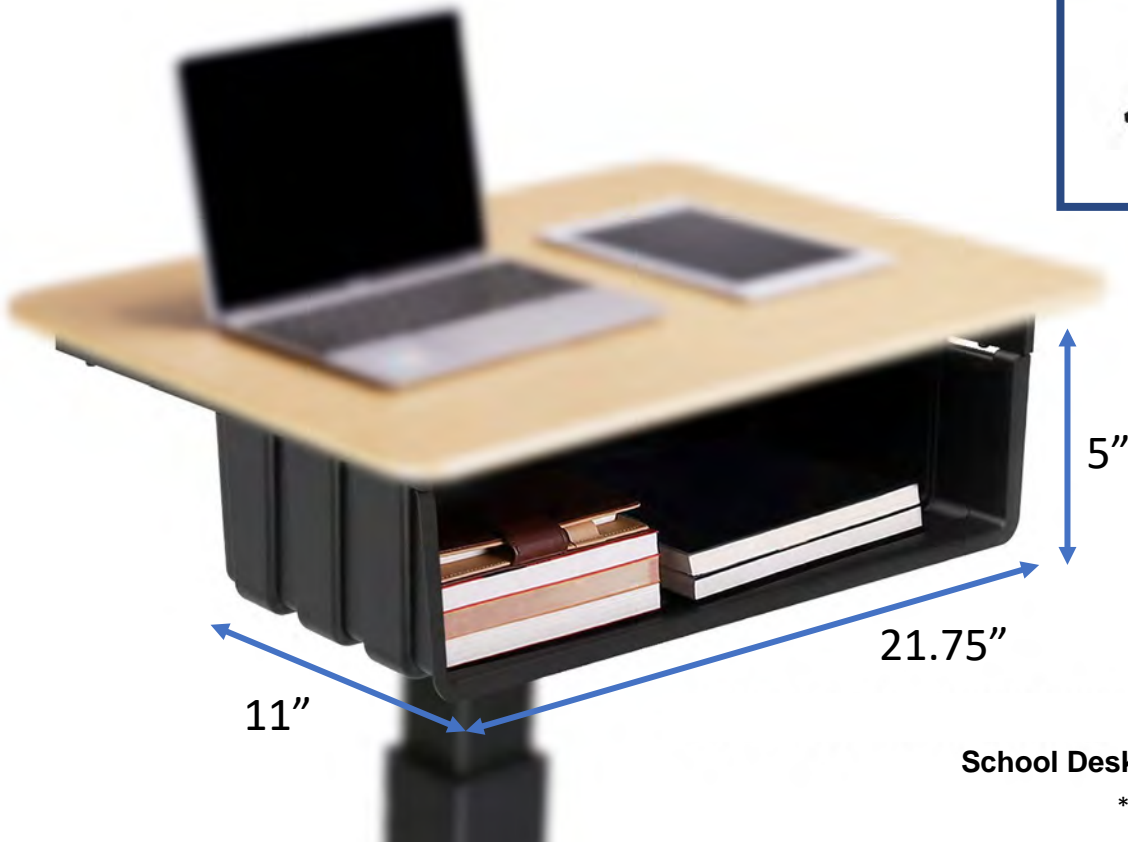

School Desk sold separately

\* INSIDE DIMENSIONS

### MSD-BB SHIPPING SPECS

Master Carton of 4 units

<b>CARTON DIMENSIONS (H X D X W)</b>	24.25" x 12.5" x 6.5"
<b>WEIGHT</b>	2.15 LBS
<b>UPC</b>	6-93285-00120-8

- Book box for MSD-28 fits under the top of Rocelco 28" sit-to-stand mobile school desk & provides a place for students to store their books.
- Add this large Book Box to your Rocelco MSD-28" Wide Sit-to-Stand Mobile School Desk (sold separately) for a convenient storage space for books and supplies.





# MSD-40

## Mobile Sit-to-Stand Desk



### MSD-40 SHIPPING SPECS

<b>CARTON DIMENSIONS (H X D X W)</b>	12" x 43" x 23.25"
<b>WEIGHT</b>	72 LBS
<b>UPC</b>	6-93285-00096-6

- Desktop rises to 49" and lowers down to 31" (above floor), to optimize the ergonomic work position for people of all heights.
- Ergonomic retractable keyboard tray sits 26.5" above floor at lowest position, for comfortable keyboarding when seated.
- Use as a standalone workstation or as an extension to your current desk.
- Wide 40" top can hold up to 2 monitors, a laptop and more.
- Grommet hole allows you to route cables or to install a monitor arm.
- Includes feet and locking casters, so you can create a fixed or mobile workstation.



# EDR

## Electric Desk Riser 37.4" Wide

*Smooth quiet up/down motion at the touch of a button*



### EDR SHIPPING SPECS

<b>CARTON DIMENSIONS (H X D X W)</b>	7" x 38.75" x 21"
<b>WEIGHT</b>	39.2 LBS
<b>UPC</b>	6-93285-00172-7

- Large 37.4" x 15.75" work surface.
- EVR Enhanced Vertical Range from 4.7" to 19.7".
- Electric lift system raises up to 33 lbs.
- Rear grommet for optional monitor arm.
- Full size 31.8" x 11.8" fixed keyboard tray holds keyboard or laptop.
- 10.5" wide slot holds tablet or phone.
- Smooth quiet up/down motion at the touch of a button.
- Includes 4 AC outlets and 2 USB 2.0 ports on the desktop



# EDR-DM2

Electric Desk Riser 37.4" Wide black + Dual Monitor Arm

*Smooth quiet up-down motion at the touch of a button*



## EDR-DM2 SHIPPING SPECS

<b>CARTON DIMENSIONS (H X D X W)</b>	7" x 38.75" x 21"
<b>WEIGHT</b>	47.4 LBS
<b>UPC</b>	6-93285-00173-4

- Large 37.4" x 15.75" work surface.
- EVR Enhanced Vertical Range from 4.7" to 19.7".
- Electric lift system raises up to 33 lbs (including monitor arm)
- Rear grommet for optional monitor arm.
- Full size 31.8" x 11.8" fixed keyboard tray holds keyboard or laptop.
- 10.5" wide slot holds tablet or phone.
- Smooth quiet up/down motion at the touch of a button.
- Dual double articulated full motion monitor arm holds 2 x 13"-27" LED monitors.
- Includes 4 AC outlets and 2 USB 2.0 ports on the desktop





# DM1

Single Monitor Mount for Desks & Adjustable Desk Risers



## DM1 SHIPPING SPECS

*Master Carton of 4 units*

<b>CARTON DIMENSIONS (H X D X W)</b>	9.5" x 19.5" x 13.5"
<b>WEIGHT</b>	34.4 LBS
<b>UPC</b>	6-93285-00046-1

- Fits one 13"- 32" LCD/LED monitors up to 8 kg/17.6 lbs. each.
- Mounts to any surface up to 8.8cm/3.5" thick.
- Clamp or grommet hole mounting.
- Works with most adjustable desk risers, including the Rocelco EADR2 & DADR2 with grommet hole mounting.
- Fits VESA 75x75mm & 100x100mm.
- Double articulated arms make it easy to adjust monitors to any desired position.
- Tilts  $\pm 45^\circ$ , swivels  $180^\circ$  & rotates  $360^\circ$ .
- Monitor mounts in landscape (horizontal) or portrait (vertical) position.
- Adjustable height along pole for ideal ergonomic position.
- Cable management clips included.



# DM2

Dual Monitor Mount for Desks & Adjustable Desk Risers

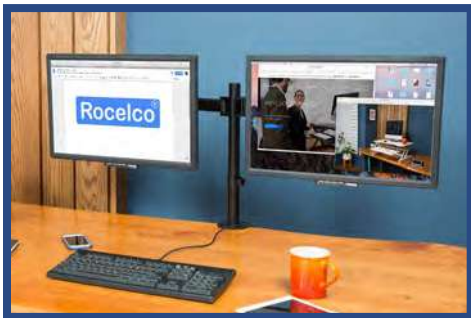

## DM2 SHIPPING SPECS

*Master Carton of 4 units*

<b>CARTON DIMENSIONS (H X D X W)</b>	10.5" x 19.5" x 12.75"
<b>WEIGHT</b>	44 LBS
<b>UPC</b>	6-93285-00069-0

- Fits two 13"- 27" LCD/LED monitors up to 8 kg/17.6 lbs. each.
- Mounts to any surface up to 8.8cm/3.5" thick.
- Choice of clamp or grommet mounting – both included.
- Works with most adjustable desk risers, including the Rocelco EADR2, DADR2, DADR-40, DADR-46, CADR-46 & MSD-40 with grommet hole mounting.
- Fits VESA 75x75mm & 100x100mm.
- Double articulated arms make it easy to adjust monitors to any desired position.
- Tilts  $\pm 45^\circ$ , swivels  $180^\circ$  & rotates  $360^\circ$ .
- Monitor mounts in landscape (horizontal) or portrait (vertical) position.
- Adjustable height along 17.7" pole for ideal ergonomic position.
- Cable management clips included.



# DM3

Triple Monitor Mount for Desks & Adjustable Desk Risers



## DM3 SHIPPING SPECS

<b>CARTON DIMENSIONS (H X D X W)</b>	5.5" x 24" x 12"
<b>WEIGHT</b>	15.85 LBS
<b>UPC</b>	6-93285-00095-9

- Mounts 3 monitors (13"- 27" up to 8kg/17.6 lbs. each) to any surface up to 8.8cm/3.5" thick.
- Clamp or grommet hole mounting
- Works with desks or adjustable desk risers, including the Rocelco DADR-46 & CADR-46.
- Fits VESA 75x75mm & 100x100mm.
- Double articulated arms make it easy to adjust monitors to any desired position.
- Tilts  $\pm 45^\circ$ , swivels  $180^\circ$  & rotates  $360^\circ$ .
- Monitor mounts in landscape (horizontal) or portrait (vertical) position.
- Adjustable height along 17.75" height pole for ideal ergonomic position.
- Cable management clips included.





# DM4 Quad Monitor Arm

Includes two complete DM2 dual monitor arms with two sets of desk clamps and grommet mounts, plus a connecting sleeve.

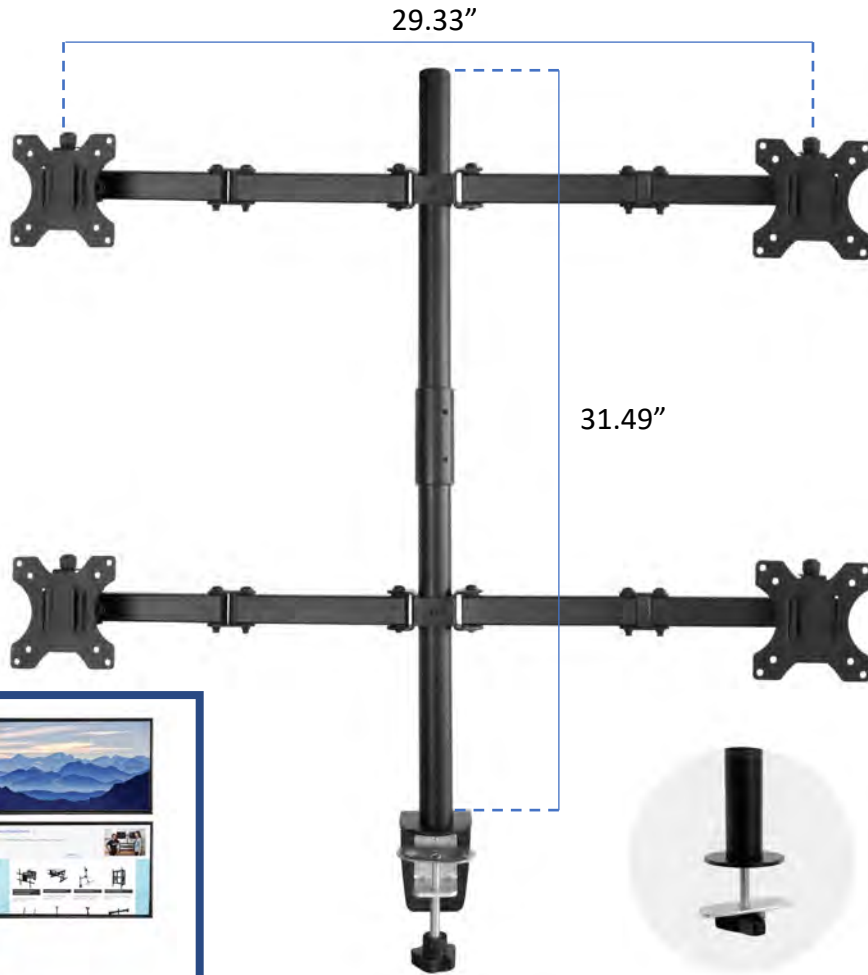

## DM4 SHIPPING SPECS

Master Carton of 3 units

<b>CARTON DIMENSIONS (H X D X W)</b>	13.39" x 18.3" x 18.3"
<b>WEIGHT</b>	51.8 LBS
<b>UPC</b>	6-93285-00107-9

- Mounts 4 monitors (13" - 27" up to 8kg/17.6 lbs. each) to any desk up to 8.9cm/3.5" thick.
- Four double articulated arms make it easy to position screens exactly where you want them.
- Monitors may be mounted in 2x2 stacked (illustrated) or side by side pattern, with choice of landscape (horizontal) or portrait (vertical) orientation. Includes a connecting sleeve for vertically stacked mounting.
- Includes 2 sets of clamp and grommet mounts.
- Fits VESA 75x75mm & 100x100mm.
- Tilts  $\pm 45^\circ$ , swivels  $180^\circ$  & rotates  $360^\circ$ .
- Adjustable height along 31.5" pole for ideal ergonomic position.
- Cable management clips included.
- Helps achieve comfortable ergonomic position to reduce neck strain and maximize your productivity.



# MA1

## Single Monitor Arm with Motion Assist

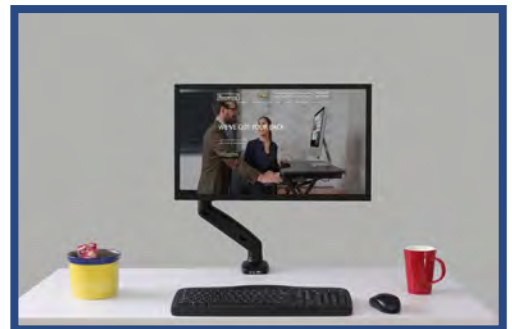

### MA1 SHIPPING SPECS

*Master Carton of 6 units*

<b>CARTON DIMENSIONS (H X D X W)</b>	24" x 15.5" x 17"
<b>WEIGHT</b>	38 LBS
<b>UPC</b>	106-93285-00117-5

- Monitor arm will support a 13" - 27" screen up to 14.3 lbs.
- Gas spring motion assist allows easy adjustments for comfortable viewing. No tools required.
- USB 2.0 and multimedia ports offer convenient way to connect and charge your devices.
- Swiveling design lets you easily switch between portrait and landscape mode.
- Keyhole Pattern: allows for easy installation.
- Cable channels help you maintain clutter-free workspace.
- Clamp and grommet mount included.



# MA2

## Double Monitor Arm with Motion Assist



### MA2 SHIPPING SPECS

*Master Carton of 3 units*

<b>CARTON DIMENSIONS (H X D X W)</b>	7.8" x 19" x 28.5"
<b>WEIGHT</b>	31.5 LBS
<b>UPC</b>	106-93285-00118-2

- Each arm will support a 13" - 27" screen up 14.3 lbs.
- Gas spring motion assist allows easy adjustments for comfortable viewing. No tools required.
- USB 2.0 and multimedia ports offer convenient way to connect and charge your devices.
- Swiveling design lets you easily switch between portrait and landscape mode.
- Keyhole Pattern: allows for easy installation.
- Cable channels help you maintain clutter-free workspace.
- Clamp and grommet mount included.



# DMS

## Dual Monitor Stand AC-USB

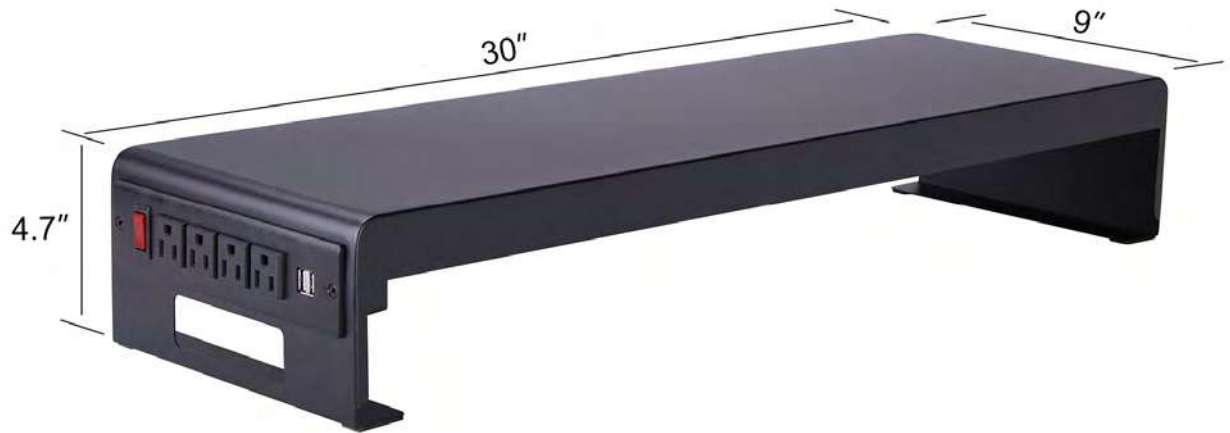

### DMS SHIPPING SPECS

*Master Carton of 6 units*

<b>CARTON DIMENSIONS (H X D X W)</b>	32.75" x 21.5" x 17.75"
<b>WEIGHT</b>	58.42 LBS
<b>UPC</b>	6-93285-00110-9

- 30" wide monitor stand is large enough for two monitors.
- 4 UL approved AC outlets plus two USB 2.0 charging ports.
- Includes extra long 10ft. power cord.
- Works with regular desks, standing desks or sit-stand desk risers.
- Cable management slot.





# MAFM

## Medium Anti-Fatigue Mat

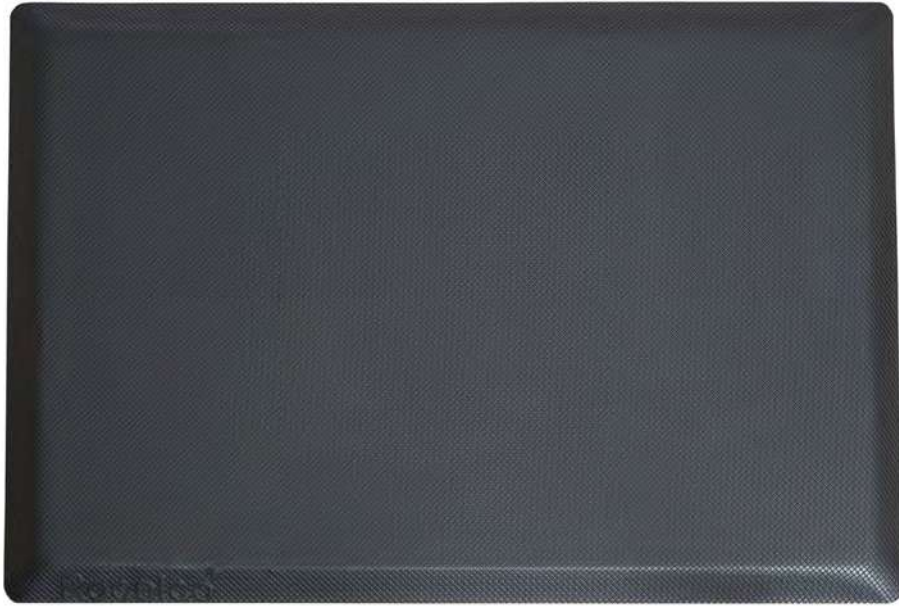

### MAFM SHIPPING SPECS

*Master Carton of 10 units*

<b>CARTON DIMENSIONS (H X D X W)</b>	21.5" x 31.5" x 11"
<b>WEIGHT</b>	38.6 LBS
<b>UPC</b>	6-93285-00031-7

- Perfect 30" x 20" size provides plenty of room to move around but can still fit in to the kneehole of a standard desk or built-in when it is not being used.
- 3/4" commercial grade thickness provides hours of comfort & stability.
- Advanced multi-layer construction with a comfortable "leather like" top surface.
- Non-slip bottom helps keep the anti-fatigue from moving around.
- Beveled edges help to reduce tripping issues.
- Supports your back, hips, knees & feet so you get all the benefits of standing while you work.
- Shipped flat to prevent any curling on the edges.
- Durable materials will not break down, even after years of use.
- Neutral black finish goes with every décor.



# MTOPO

Topographical Energizing Mat



## MTOPO SHIPPING SPECS

*Master Carton of 6 units*

<b>CARTON DIMENSIONS (H X D X W)</b>	20" x 25.5" x 15.5"
<b>WEIGHT</b>	30.95 LBS
<b>UPC</b>	6-93285-00097-3

- Perfect 25" x 19" size provides plenty of room to move around (and room for feet of all sizes!).
- Supports your back, hips, knees and feet, so you can get all the benefits of standing while you work.
- Raised corners and moveable ball allow you to work your toes and keep your core active.
- Raised sections and massage nubs allow you to stretch your legs and massage your feet.
- Supports your back, hips, knees & feet so you get all the benefits of standing while you work.
- Non-slip bottom helps keep the MTOPO from moving around.
- Durable 100% polyurethane construction will not break down, even after years of use.
- Neutral black finish goes with every décor.



# EFD

## Sit-to-stand Workstation clamps on desk



### EFD SHIPPING SPECS

<b>CARTON DIMENSIONS (H X D X W)</b>	11" x 28.5" x 11.25"
<b>WEIGHT</b>	45.15 LBS
<b>UPC</b>	106-93285-00066-6

- Mounts to your current desk or credenza and includes clamp and grommet brackets.
- Range of motion over 14" with gas spring arm.
- Monitor height independently adjustable.
- Sturdy commercial-grade steel and aluminum construction.
- Space saving: keyboard tray flips up and EFD can easily be swung out of the way when you need to use your entire desk.
- The space-saving clamp-on design is perfect for restricted-space applications such as industrial, restaurant, medical, dental etc.
- The monitor mount will hold up to a 27" monitor. With the EFD+2 accessory kit (sold separately), you can hold 2 monitors, up to 24" each.
- The large 26.5" x 9" keyboard tray will hold your keyboard and mouse. Optional EFT accessory tray (sold separately) holds even more.
- Holds up to 24 lbs total weight, including monitor(s), keyboard and accessories.



# EFD+2

Double Monitor Arm for EFD

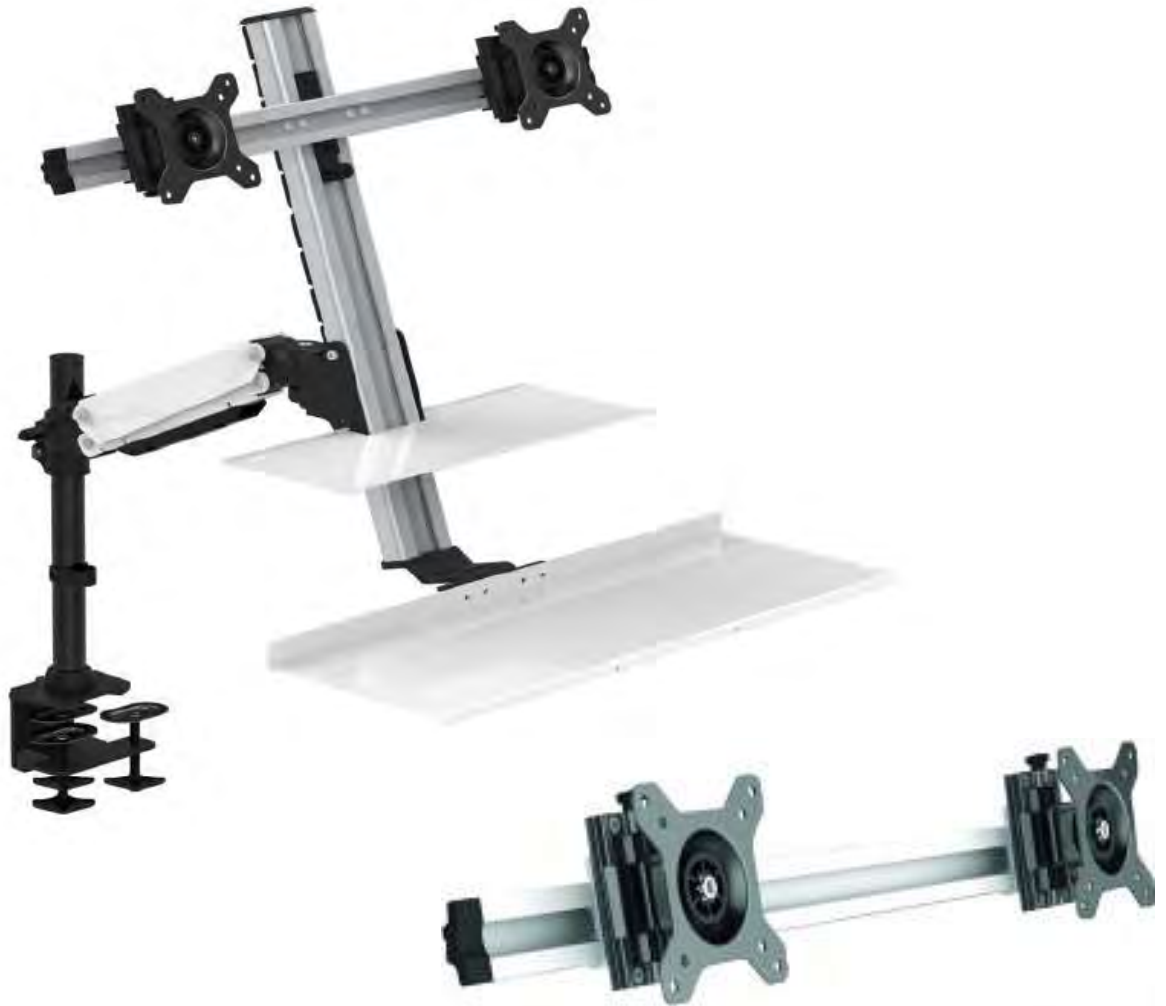

## EFD+2 SHIPPING SPECS

<b>CARTON DIMENSIONS (H X D X W)</b>	11" x 28" x 11"
<b>WEIGHT</b>	39.35 LBS
<b>UPC</b>	6-93285-00067-6

- Double monitor arm for converts the EFD Workstation to allow it to hold two monitors. The adjustable monitor mounts will move up and down separately from the keyboard tray and will hold up to two 24" monitors.
- Converts the EFD, ergonomic floating desk to hold 2 monitors.
- Adjustable monitor mounts will move up and down separately from the keyboard tray
- Hold up to two 24" monitors
- EFD+2 includes one monitor mount. The second monitor mount is included with the basic EFD.





# EFD+T

Tray for the EFD



## EFD+T SHIPPING SPECS

<b>CARTON DIMENSIONS (H X D X W)</b>	8.75" x 17.5" x 13.5"
<b>WEIGHT</b>	22.95 LBS
<b>UPC</b>	6-93285-00125-3

- Accessory Tray for EFD, 16" – White
- An accessory tray for the EFD desk riser
- 15.75" x 6" tray
- Adds extra working space for your Phone, Calculator, pad, pens, etc.



# LED-20-3

LED Workspace Lighting

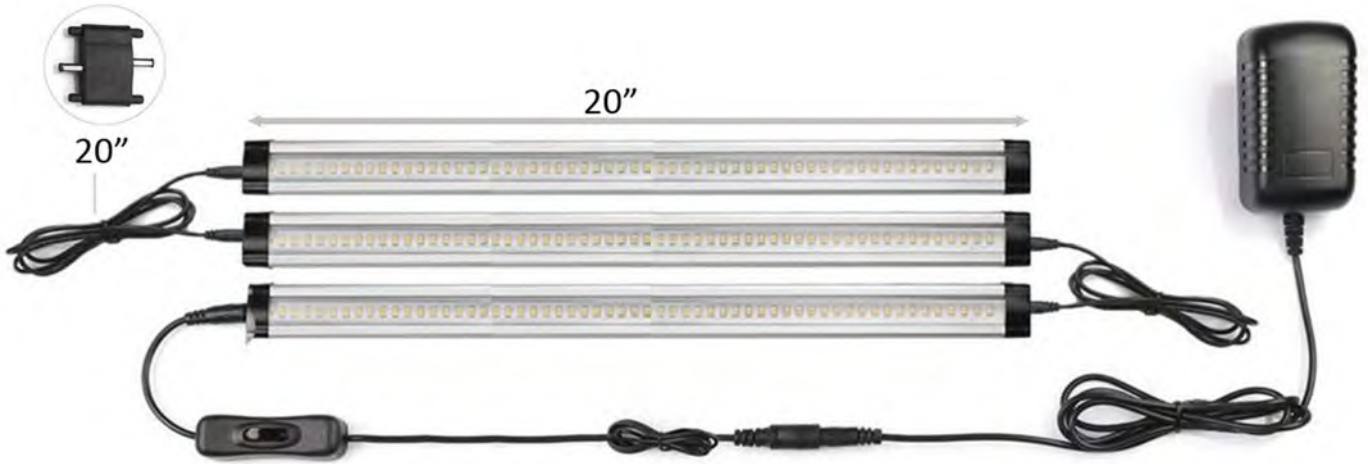

## LED-20-3 SHIPPING SPECS

*Master Carton of 20 units*

<b>CARTON DIMENSIONS (H X D X W)</b>	11.75" x 21.75" x 13"
<b>WEIGHT</b>	33.36 LBS
<b>UPC</b>	6-93285-00094-2

- LED task lighting kit includes three 20" LED light bars, daisy chain and hard clip connectors (allow you to spread the lights out to 100" with daisy chain connectors or create a single 60" light bar with hard clip connectors).
- Includes all mounting hardware. UL approved power supply, with a single switch to control all lights.
- Includes everything necessary for 1-3 work areas
- 1350 lumens