



Ceiling Trim Kit for VMAX2/Spectrum Series

User Guide



Parts List

Please make sure all parts listed below are included before assembly.



1. Suspension Bar x 4 pcs

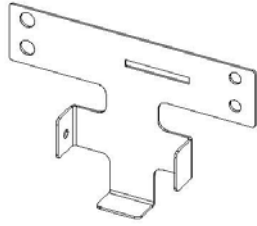

2. Left Bracket x 1 pc

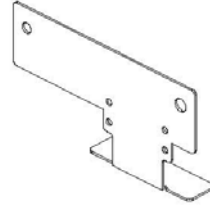

3. Left Plank x 1 pc



4. Ceiling Panel x 4 pcs

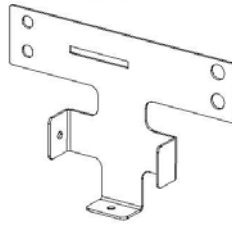

5. Right Bracket x 1 pc

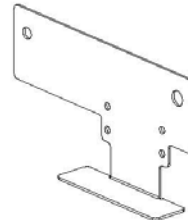

6. Right Plank x 1 pc



7. Self-Drilling Screws x 8 pcs

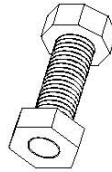

8. Screw + Nut x 12 pcs

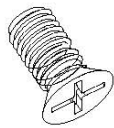

9. M5 Screws x 16 pcs

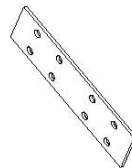

10. Connecting Sheet x 2 pcs

ASSEMBLY

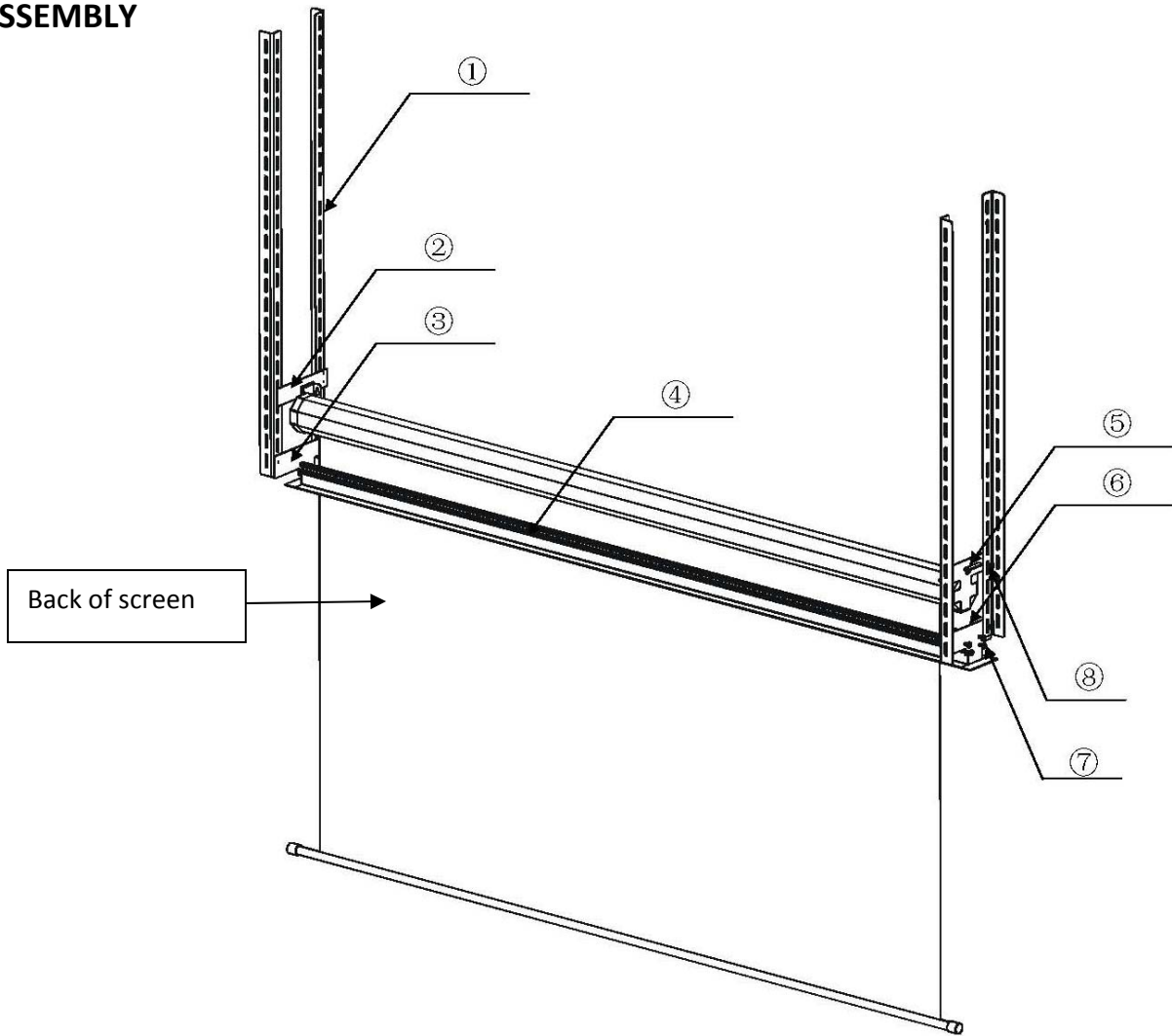

Step 1: Install the screen's left and right side end caps into the **LEFT (2)** and **RIGHT (5) BRACKETS** and secure them with the **M5 screws (9)** as shown in the diagram below.

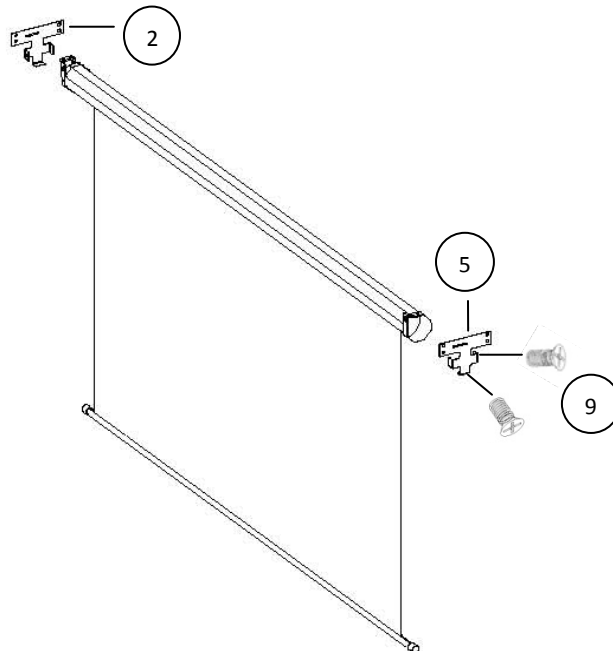

Step 2: Join the four **CEILING PANELS (4)** as show below and connect them with together with the **CONNECTION SHEET (10)** using the **M5 screws (9)**.

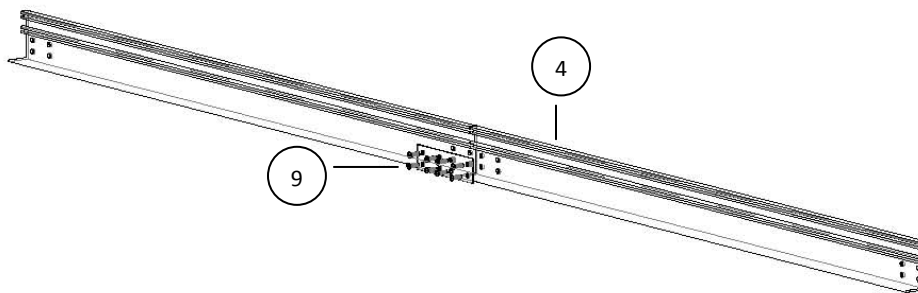

Step 3: Attach the **LEFT (3)** and **RIGHT (6)** **PLANK** on each end of the **CEILING PANEL (4)** with the **SELF-DRILLING SCREWS (7)** as shown below.

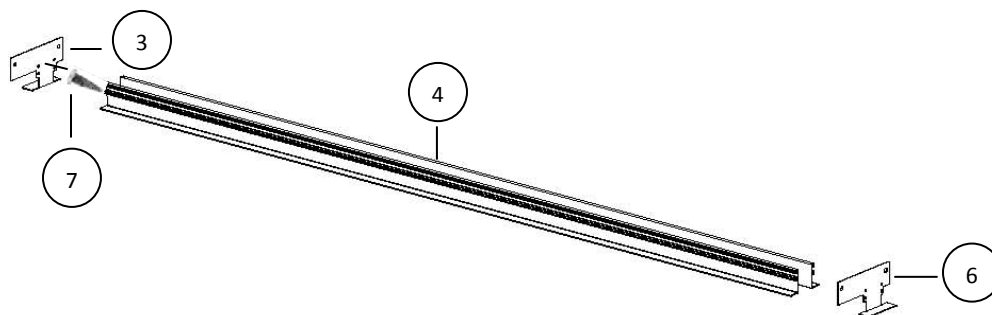

Step 4: Lastly, attach the **SUPPORT BARS (1)** to the **LEFT** and **RIGHT BRACKETS** and **PLANKS** using the **SCREW + NUT (8)** to finish the assembly.

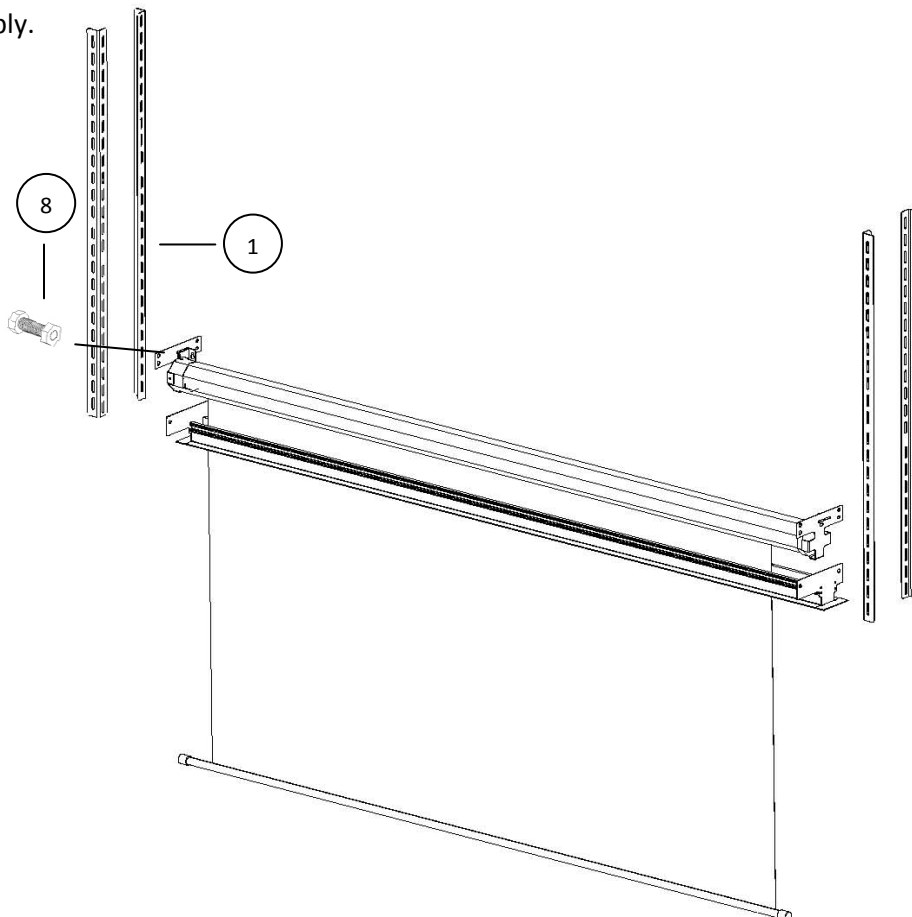

Example of Ceiling Trim Kit installed

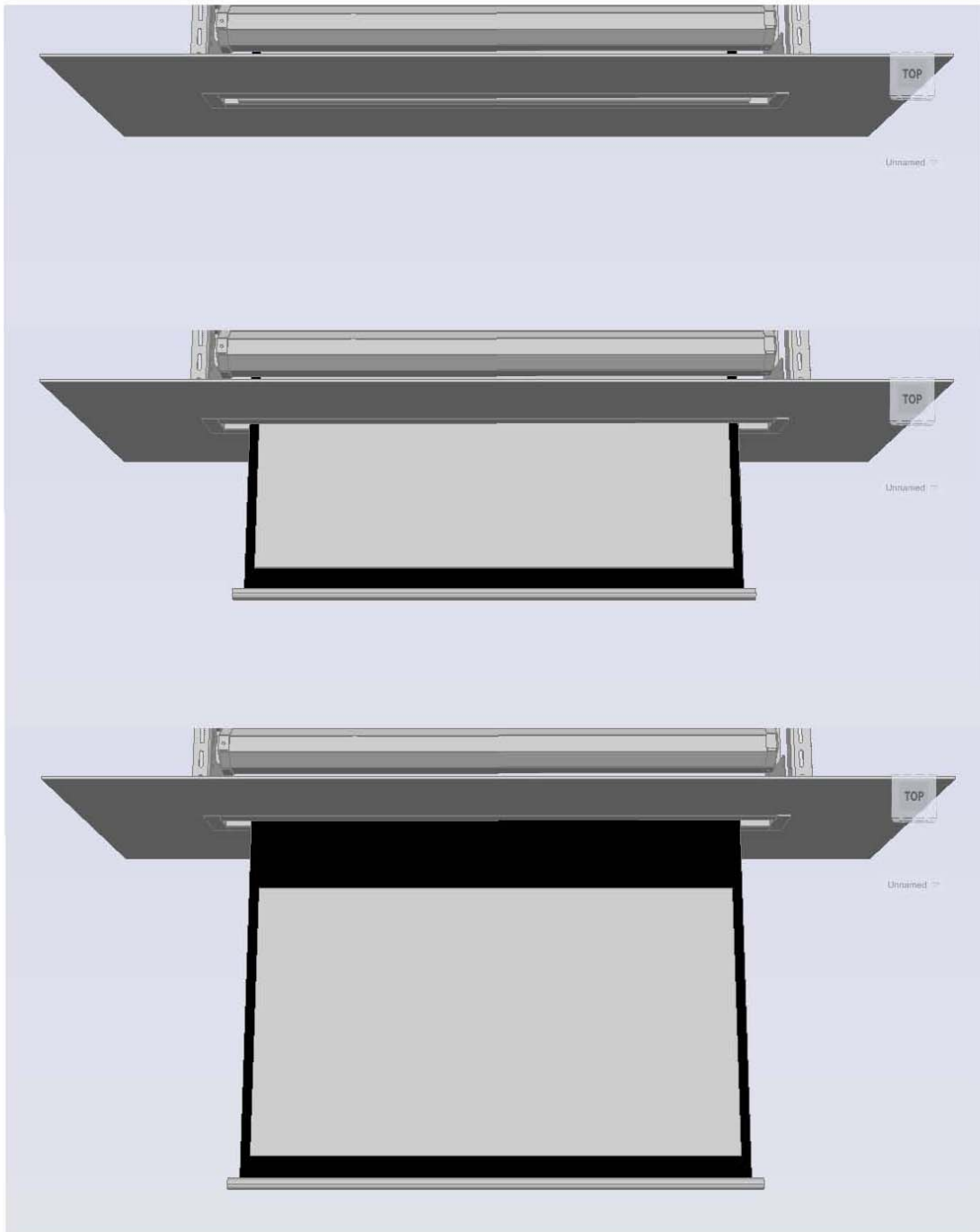

Dimensions Table/Line Drawings

Unit: mm						
Models	Suspension Bars Distance (A)	Suspension Bar Hole Distance (A1)	Height from Ceiling Panel to Suspension Bar (B)	Suspension Bar Height (B1)	Suspension Bar Hole Distance (B2)	Distance Between Suspension Bars (C)
ZCVMAX99S	2116	2092	960	900	50	177
ZCVMAX113S	2395	2371	960	900	50	177
ZCVMAX119S	2501	2477	960	900	50	177
ZCVMAX136S	2806	2782	960	900	50	177
ZCVMAX153S	3106	3082	960	900	50	177
ZCVMAX84H	2197	2173	960	900	50	177
ZCVMAX92H	2395	2371	960	900	50	177
ZCVMAX100H	2573	2549	960	900	50	177
ZCVMAX106H	2708	2684	960	900	50	177
ZCVMAX120H	3020	2996	960	900	50	177
ZCVMAX135H	3352	3328	960	900	50	177
ZCVMAX150H	3686	3662	960	900	50	177
ZCVMAX84V	2045	2021	960	900	50	177
ZCVMAX92V	2207	2183	960	900	50	177
ZCVMAX100V	2395	2371	960	900	50	177
ZCVMAX120V	2802	2778	960	900	50	177
ZCVMAX135V	3106	3082	960	900	50	177
ZCVMAX150V	3412	3388	960	900	50	177
ZCElectric125H	3132	3108	960	900	50	177
Unit: Inches						
Models	Suspension Bars Distance (A)	Suspension Bar Hole Distance (A1)	Height from Ceiling Panel to Suspension Bar (B)	Suspension Bar Height (B1)	Suspension Bar Hole Distance (B2)	Distance Between Suspension Bars (C)
ZCVMAX99S	83.3	82.4	37.8	35.4	2.0	7.0
ZCVMAX113S	94.3	93.3	37.8	35.4	2.0	7.0
ZCVMAX119S	98.5	97.5	37.8	35.4	2.0	7.0
ZCVMAX136S	110.5	109.5	37.8	35.4	2.0	7.0
ZCVMAX153S	122.3	121.3	37.8	35.4	2.0	7.0
ZCVMAX84H	86.5	85.6	37.8	35.4	2.0	7.0
ZCVMAX92H	94.3	93.3	37.8	35.4	2.0	7.0
ZCVMAX100H	101.3	100.4	37.8	35.4	2.0	7.0
ZCVMAX106H	106.6	105.7	37.8	35.4	2.0	7.0
ZCVMAX120H	118.9	118.0	37.8	35.4	2.0	7.0
ZCVMAX135H	132.0	131.0	37.8	35.4	2.0	7.0
ZCVMAX150H	145.1	144.2	37.8	35.4	2.0	7.0
ZCVMAX84V	80.5	79.6	37.8	35.4	2.0	7.0
ZCVMAX92V	86.9	85.9	37.8	35.4	2.0	7.0
ZCVMAX100V	94.3	93.3	37.8	35.4	2.0	7.0
ZCVMAX120V	110.3	109.4	37.8	35.4	2.0	7.0
ZCVMAX135V	122.3	121.3	37.8	35.4	2.0	7.0
ZCVMAX150V	134.3	133.4	37.8	35.4	2.0	7.0
ZCElectric125H	123.3	122.4	37.8	35.4	2.0	7.0

*Measurement dimensions are intended as a reference only and subject to change without notice

Note: Data Error may be ± 1 "

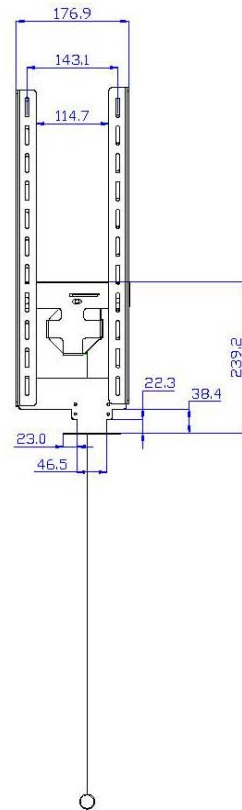
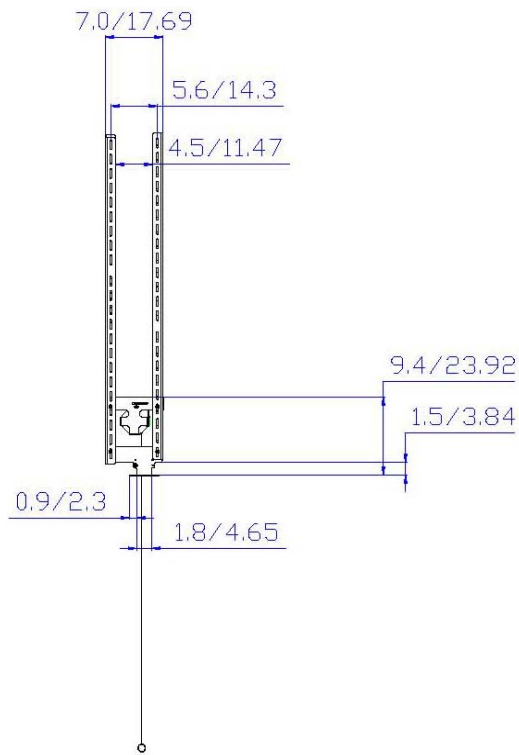
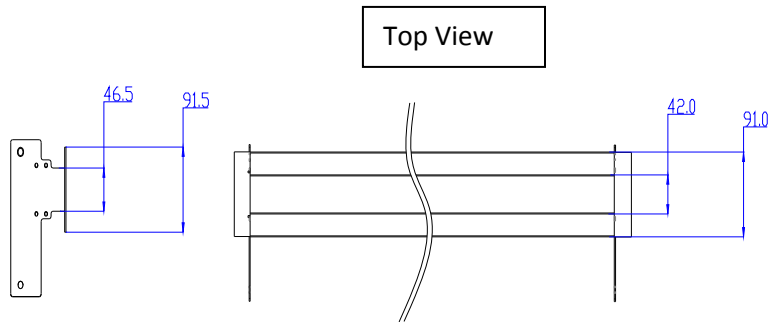
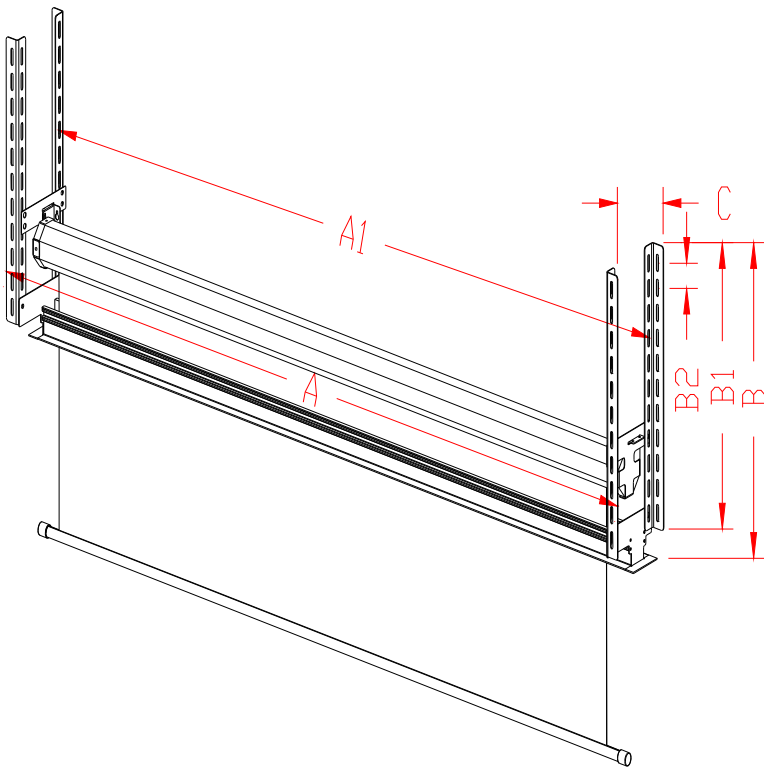

Register your warranty at www.elitescreens.com/register.html

US & Canada Tech Support & Warranty Claim

Please contact us at service@elitescreens.com or call +1 877-511-1211 #3 Service

Europe Tech Support & Warranty Claim

Please contact us at service@elitescreens.eu or call +49-(0) 40-30392958

Asia or China Tech Support & Warranty Claim

Please contact us at service@elitescreens.com.cn or call +86-(0) 755-8461-7989

Taiwan Tech Support & Warranty Claim

Please contact us at service@elitescreens.com.tw or call +886-(02)2747-8979

America: Elite Screens Inc

16410 Manning Way, Cerritos, CA 90703 USA

Tel: 877-5111211 Fax: 562-483-8498

info@elitescreens.com www.elitescreens.com

Europe: Elite Screens Europe GmbH

Lübecker Straße, 122087 Hamburg, Germany

Tel: +49-40-30392494 Fax: +49-40-49219200

info@elitescreens.eu www.elitescreens.eu

Asia: Elite Screens China Ltd.

Longxi Duimianling Industry Zone Longcheng

Longgang District, ShenZhen GuangDong, China

Tel: +86-(0)755-8461-7989 Fax: +86-(0)755-8461-7669

info@elitescreens.com.cn www.elitescreens.com.cn

Taiwan: Elite Screens Taiwan Corp.

1F. No. 38 Alley 22 Lane 66 Sec. 5 Nanjing E. Rd.

Songshan District. Taipei City 105, Taiwan

Tel: +886-(02)2747-8979 Fax: +886-(02)2747-8978

info@elitescreens.com.tw www.elitescreens.com.tw

Email contacts:

Latin America Contact:

erik.garcia@elitescreens.com

East Asia Contact:

info.ea@elitescreens.com

India Contact:

info.india@elitescreens.com

Japan Contact:

info.japan@elitescreens.com