

Wall Channel

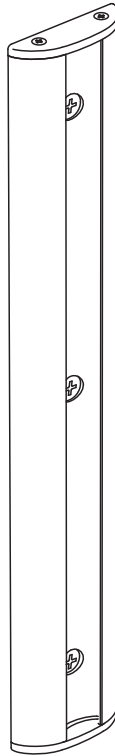

COMPONENT CHECKLIST

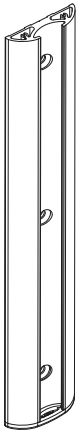

A
Wall channel
(x1)

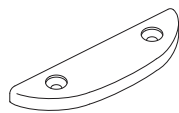

B
Top Cap
(x1)



C
Top Cap
Screws
(x2)

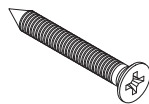

D
M6 x 50mm
Countersunk
Screw (x3)

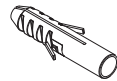

E
Nylon
Anchor (x3)

REQUIRED TOOLS

- Power Drill
- 5.5mm (1/4") Drill Bit
- 8mm (5/16") Drill Bit
- Phillips Head Screwdriver

IMPORTANT INFORMATION

- ! Please ensure this product is installed as per these installation instructions.
- ! This product is compatible with Atdec modular (AWM) products.
- ! The manufacturer accepts no responsibility for incorrect installation.

1. Install Wall Channel - Ensure all fasteners are installed

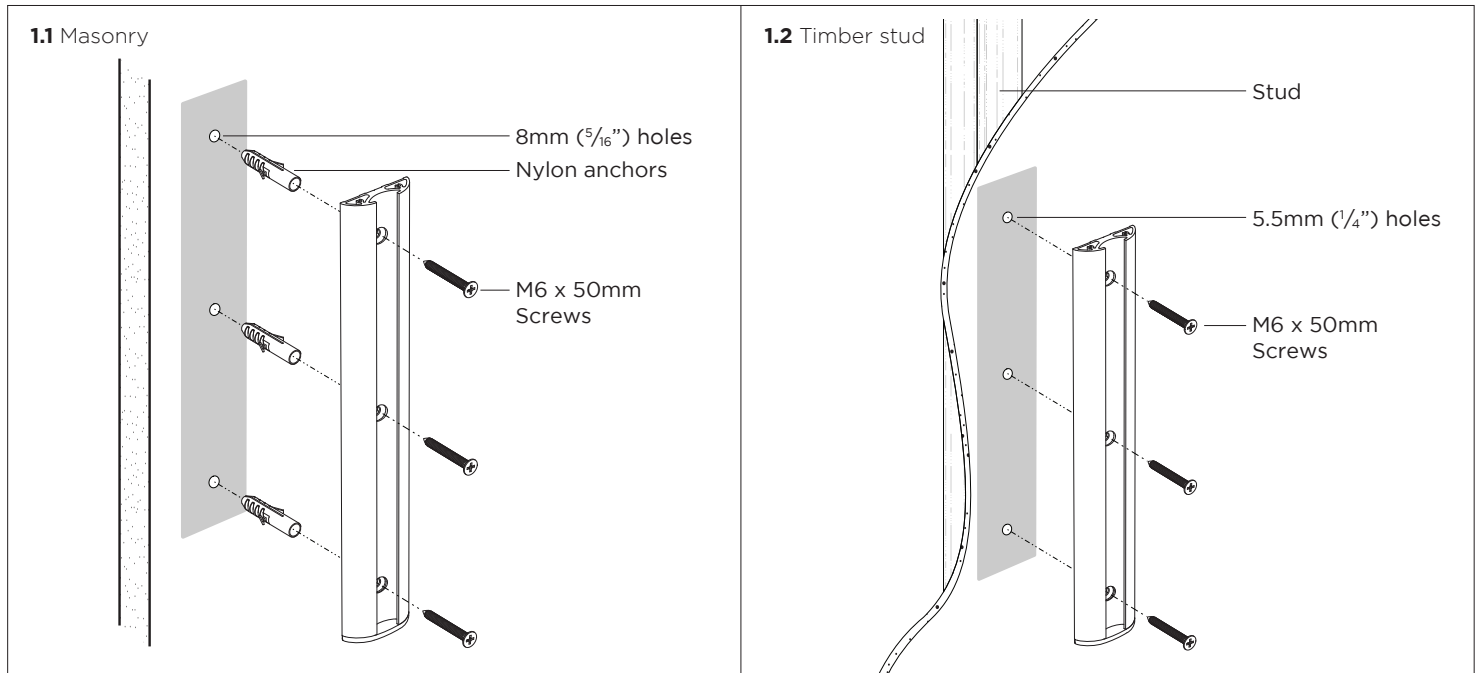

2. Mount Arm Assembly

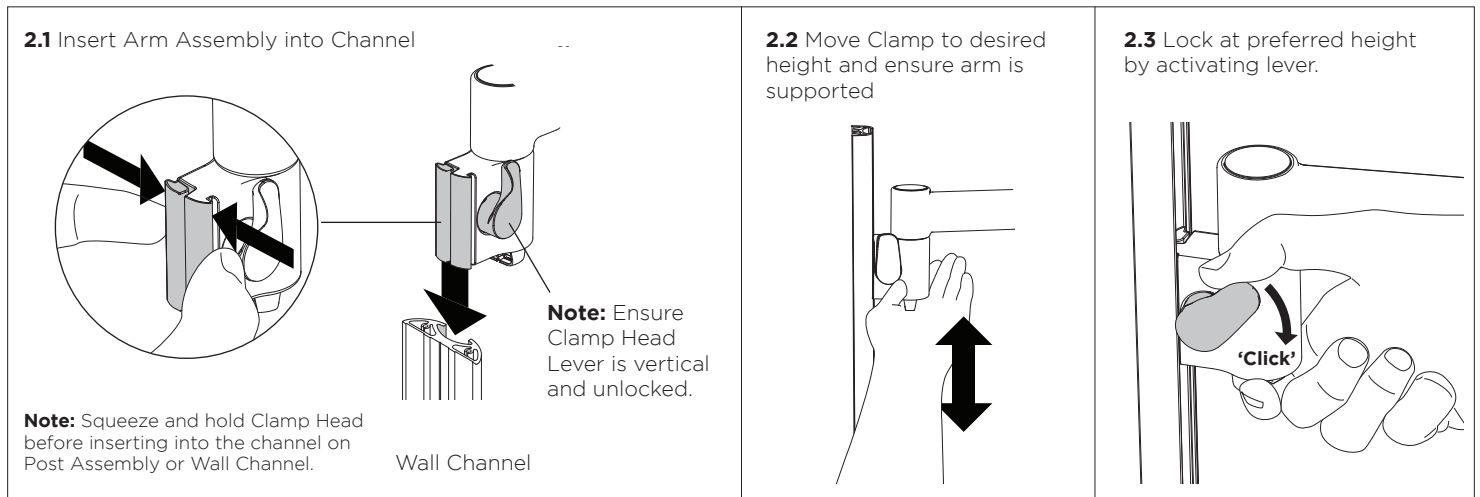

3. Install top cap

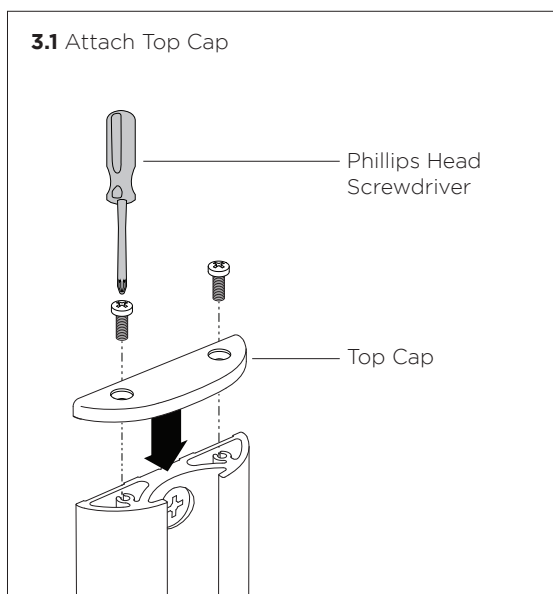

4. Cable clips

